

<p>PNP型 小功率 贴片三极管 PNP EPITAXIAL PLANAR TRANSISTOR SMD</p>	<p>S9012 对应其他工业型号 9012</p>
<ul style="list-style-type: none"> ■ Excellent hFE linearity ■ Low noise ■ Transistor Polarity: PNP ■ Transistor pinout: BEC ■ SOT-23 Package ■ Marking Code: 2T1 	

<p style="text-align: center;">Inner circuit</p>  <p style="text-align: center;">SOT-23 内部结构</p>	<p style="text-align: center;">S9012</p>  <p style="text-align: center;">SOT-23 管脚排列</p> <p style="text-align: center;">1. Base 2. Emitter 3. Collector</p>	<p style="text-align: center;">元件标识 (打印)</p>  <p style="text-align: center;">DEVICE MARKING</p>
--	---	---

■ CLASSIFICATION OF hFE

RANK	L	H
RANGE	100~200	200~300

■ MAXIMUM RATINGS

Symbol	Parameter	Value	Unit
V_{CBO}	Collector-Base Voltage	-40	V
V_{CEO}	Collector-Emitter Voltage	-25	V
V_{EBO}	Emitter-Base Voltage	-6	V
I_c	Collector Current	-500	mA
P_c	Collector Power Dissipation	300	mW
T_J, T_{stg}	Operation Junction and Storage Temperature Range	-55~+150	°C

■ ELECTRICAL CHARACTERISTICS (T_A=25°C unless otherwise noted)

Parameter	Symbol	Test conditions	MIN	MAX	UNIT
Collector-base breakdown voltage	V _{(BR)CBO}	I _C = -100μA, I _E =0	-40		V
Collector-emitter breakdown voltage	V _{(BR)CEO}	I _C = -1mA, I _B =0	-25		V
Emitter-base breakdown voltage	V _{(BR)EBO}	I _E = -100μA, I _C =0	-5		V
Collector cut-off current	I _{CBO}	V _{CB} = -40V, I _E =0		-0.1	μA
Collector cut-off current	I _{CEO}	V _{CE} = -20V, I _B =0		-0.1	μA
Emitter cut-off current	I _{EBO}	V _{EB} = -3V, I _C =0		-0.1	μA
DC current gain	h _{FE(1)}	V _{CE} = -1V, I _C = -50mA	120	400	
	h _{FE(2)}	V _{CE} = -1V, I _C = -500mA	50		
Collector-emitter saturation voltage	V _{CE(sat)}	I _C =-500mA, I _B = -50mA		-0.6	V
Base-emitter saturation voltage	V _{BE(sat)}	I _C =-500mA, I _B = -50mA		-1.2	V
Transition frequency	f _T	V _{CE} = -6V, I _C = -20mA f=30MHZ	150		MHZ

■ DIMENSION

单位 (UNIT) : mm

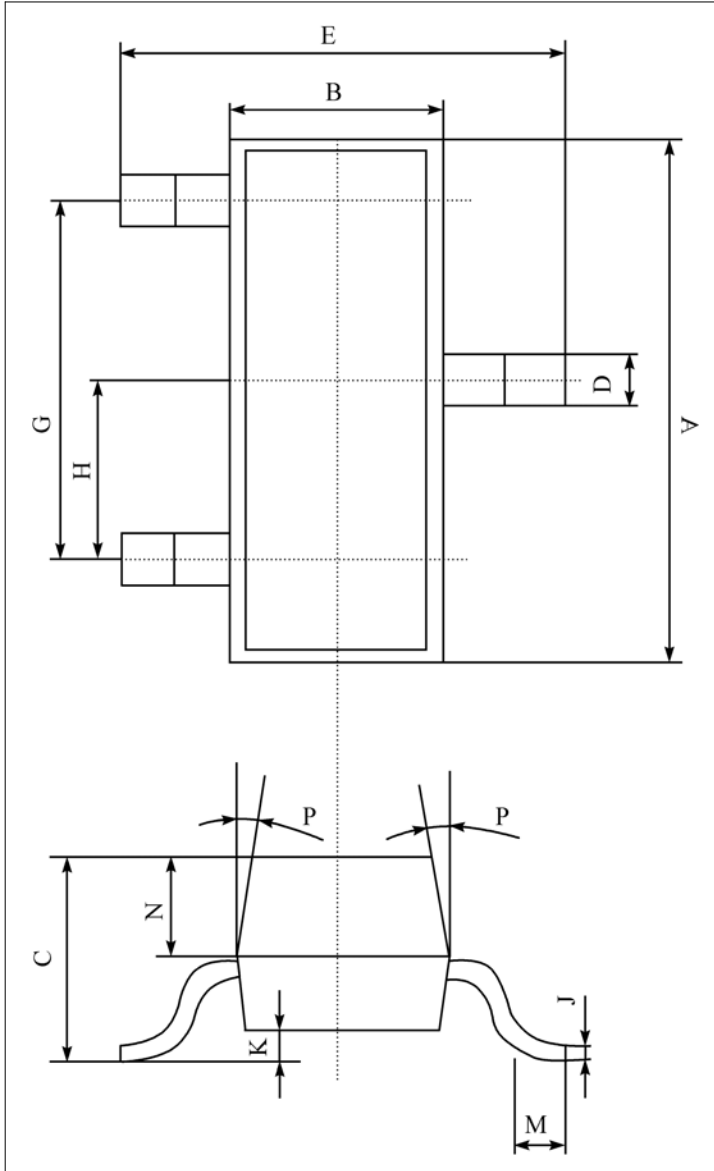

序号	数值及公差
A	2.90±0.10
B	1.30±0.10
C	1.00±0.10
D	0.40±0.10
E	2.40±0.20
G	1.90±0.10
H	0.95±0.05
J	0.13±0.05
K	0.00-0.10
M	≥0.20
N	0.60±0.10
P	7±2°

Packing
 SOT-23 包装规格
 SMD片式表面贴封装
 包装方式: 载带卷盘包装
 Tape & Reel, 3Kpcs/Reel
 每卷数量3000只 (3Kpcs/Reel)
 每盒数量45000只 (45Kpcs/BOX)
 每箱数量180000只 (180Kpcs/Cartons)

SOT-23 Tape and reel

SOT-23 Embossed Carrier Tape

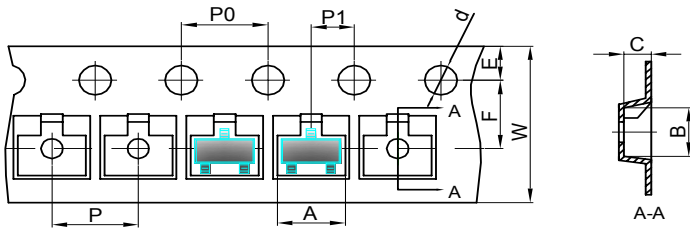

Dimensions are in millimeter										
Pkg type	A	B	C	d	E	F	P0	P	P1	W
SOT-23	3.15	2.77	1.22	Ø1.50	1.75	3.50	4.00	4.00	2.00	8.00

SOT-23 Tape Leader and Trailer

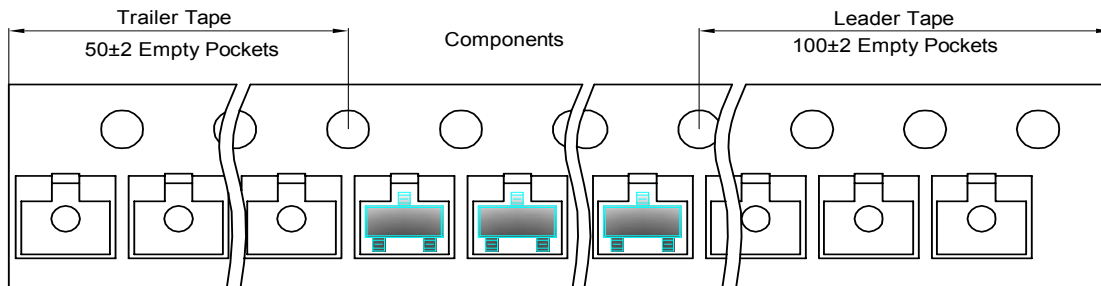

SOT-23 Reel

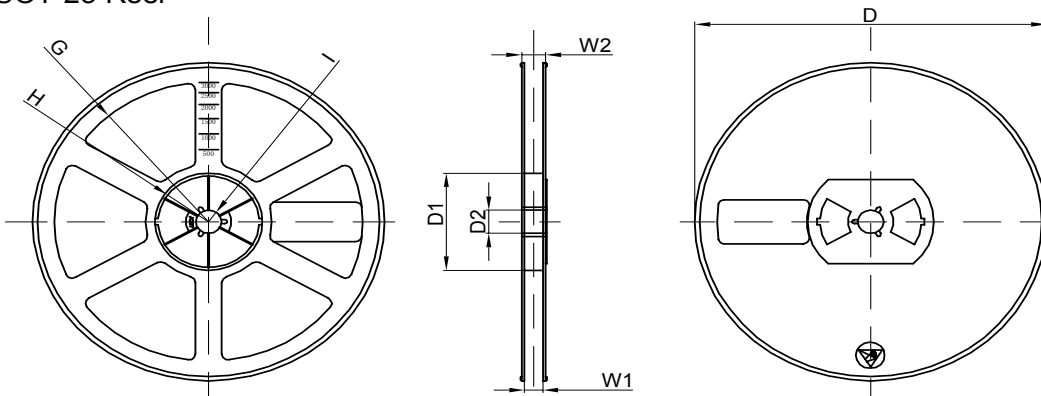

Dimensions are in millimeter								
Reel Option	D	D1	D2	G	H	I	W1	W2
7" Dia	Ø178.00	54.40	13.00	R78.00	R25.60	R6.50	9.50	12.30

REEL	Reel Size	Box	Box Size(mm)	Carton	Carton Size(mm)	G.W.(kg)
3000 pcs	7 inch	45,000 pcs	192×192×193	180,000 pcs	404×404×214	