

<p>NPN型 低频放大 小功率 贴片三极管 NPN Plastic-Encapsulate Transistors SMD</p>	<p>S8050</p> <p>对应其他工业型号</p>
<ul style="list-style-type: none"> ■ High breakdown voltage ■ Low collector-emitter saturation voltage ■ Transistor Polarity: NPN ■ Transistor pinout: BEC ■ SOT-23 Package ■ Marking Code: J3Y 	

<p style="text-align: center;">Inner circuit</p>  <p style="text-align: center;">SOT-23 内部结构</p>	<p style="text-align: center;">S8050C</p>  <p style="text-align: center;">SOT-23 管脚排列</p>	<p style="text-align: center;">元件标识 (打印)</p>  <p style="text-align: center;">DEVICE MARKING</p>
--	---	---

■ CLASSIFICATION OF hFE

RANK	L	H
RANGE	100~200	200~300

■ MAXIMUM RATINGS

Parameter	Symbol	Value	Unit
Collector-Base Voltage	V_{CBO}	40	V
Collector-Emitter Voltage	V_{CEO}	25	V
Emitter-Base Voltage	V_{EBO}	5	V
Collector Current	I_c	200	mA
Collector Power Dissipation	P_c	300	mW
Operation Junction and Storage Temperature Range	T_J, T_{stg}	-55~+150	°C

■ ELECTRICAL CHARACTERISTICS (T_A=25°C unless otherwise noted)

Characteristic	Test Condition	Symbol	Min	Typ	Max	Unit
Collector Cutoff Current	V _{CB} =40V, I _E =0	I _{CBO}	--	--	0.1	μA
Emitter Cutoff Current	V _{EB} =5V, I _C =0	I _{EBO}	--	--	0.1	μA
Collector-Base Breakdown Voltage	I _E =0 I _C =100μA	V _{(BR)CBO}	40	--	--	V
Collector-Emitter Breakdown Voltage	I _E =0 I _C =10mA	V _{(BR)CEO}	25	--	--	V
Emitter Cutoff Current	I _C =0, I _E =100μA	V _{(BR)EBO}	5	--	--	V
DC Current Gain	I _C =100mA, V _{CE} =1V	hFE (1)	85	--	400	
	I _C =200mA, V _{CE} =1V	hFE	40	--	--	
Collector-Emitter Saturation Voltage	I _C =200mA, I _B =50mA	V _{CE(sat)}	--	--	0.6	V
Base-Emitter Voltage	V _{CE} =1V, I _C =10mA	V _{CE(sat)}	--	0.8	1.0	V
Current-Gain-Bandwidth Product	V _{CE} =5V, I _C =10mA	f _T	100	120	--	MHz
Collector Output Capacitance	V _{CB} =10V, I _E =0, f=1MHz	C _{ob}	--	13	30	pF

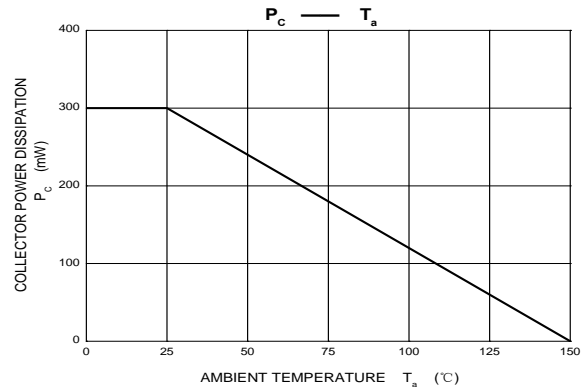
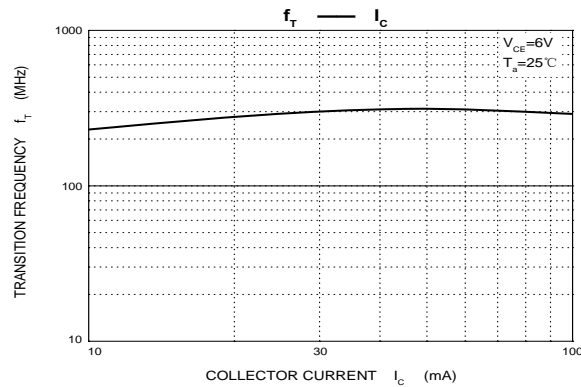
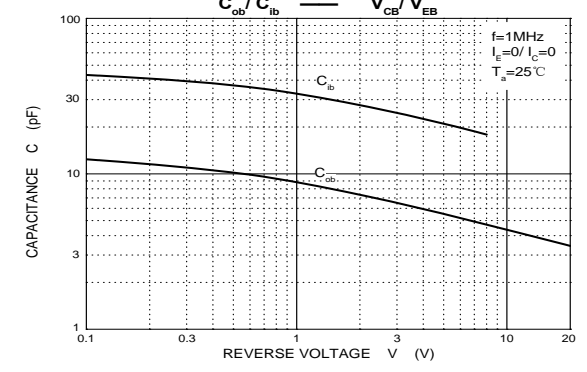
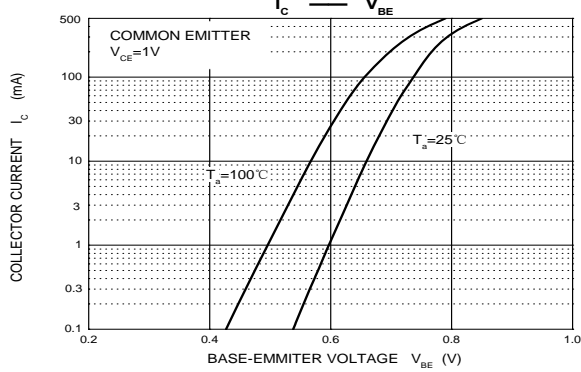
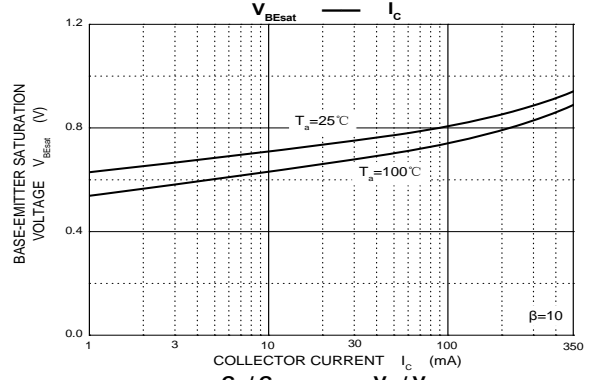
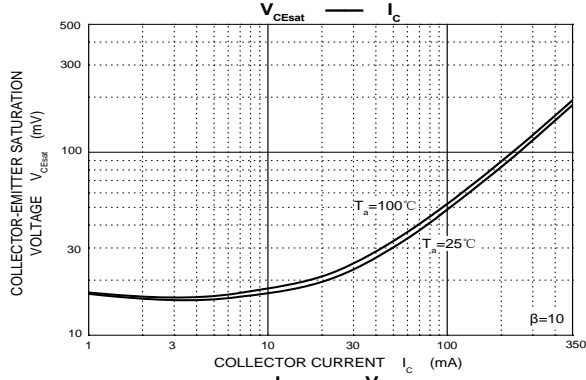
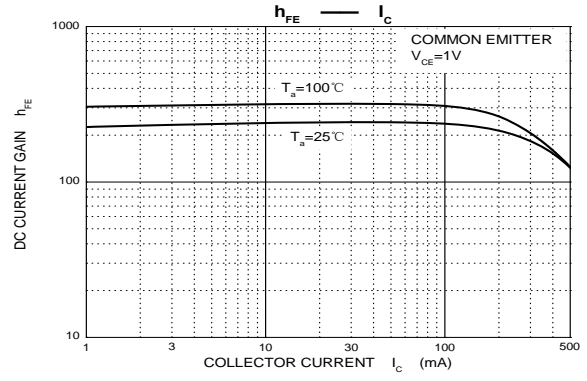
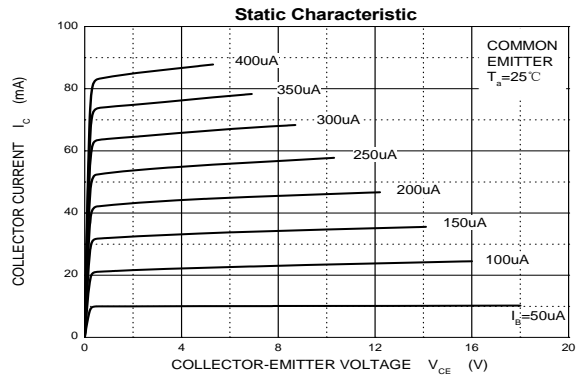

■ DIMENSION

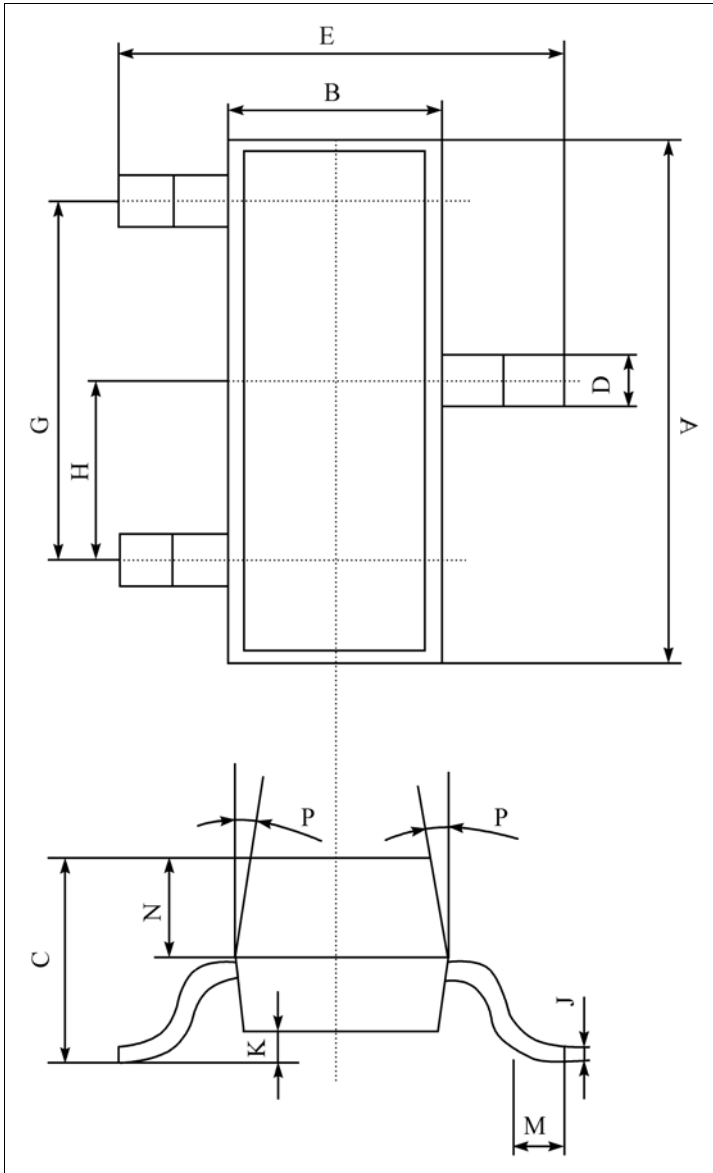

单位 (UNIT) : mm

序号	数值及公差
A	2.90±0.10
B	1.30±0.10
C	1.00±0.10
D	0.40±0.10
E	2.40±0.20
G	1.90±0.10
H	0.95±0.05
J	0.13±0.05
K	0.00-0.10
M	≥0.20
N	0.60±0.10
P	7±2°
<p>Packing SOT-23 包装规格 SMD片式表面贴封装 包装方式: 载带卷盘包装 Tape & Reel, 3Kpcs/Reel 每卷数量3000只 (3Kpcs/Reel) 每盒数量45000只 (45Kpcs/BOX) 每箱数量180000只 (180Kpcs/Cartons)</p>	

SOT-23 Tape and reel

SOT-23 Embossed Carrier Tape

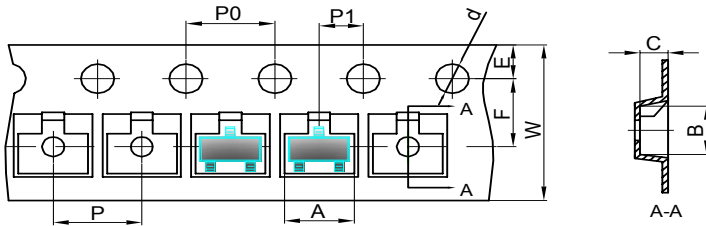

Dimensions are in millimeter											
Pkg type	A	B	C	d	E	F	P0	P	P1	W	
SOT-23	3.15	2.77	1.22	Ø1.50	1.75	3.50	4.00	4.00	2.00	8.00	

SOT-23 Tape Leader and Trailer

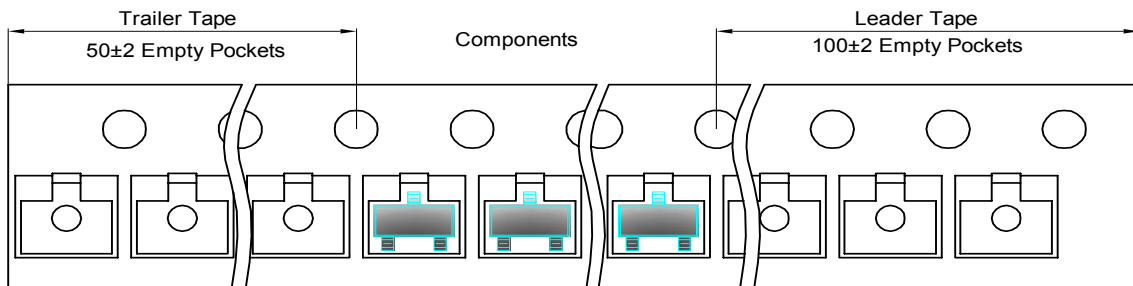

SOT-23 Reel

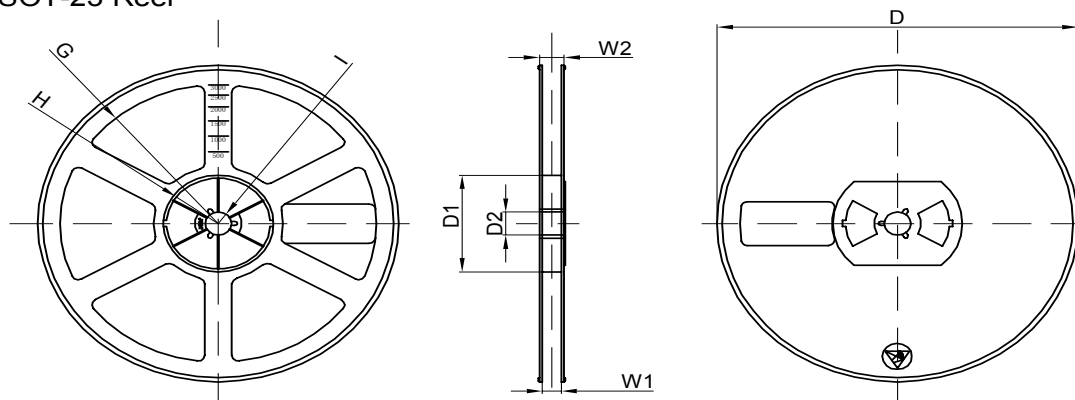

Dimensions are in millimeter								
Reel Option	D	D1	D2	G	H	I	W1	W2
7" Dia	Ø178.00	54.40	13.00	R78.00	R25.60	R6.50	9.50	12.30

REEL	Reel Size	Box	Box Size(mm)	Carton	Carton Size(mm)	G.W.(kg)
3000 pcs	7 inch	45,000 pcs	192×192×193	180,000 pcs	404×404×214	