

Features

- 30V/150A,
 $R_{DS(ON)} = 1.4m\Omega$ (typ.) @ $V_{GS} = 10V$
 $R_{DS(ON)} = 1.9m\Omega$ (typ.) @ $V_{GS} = 4.5V$
- 100% UIS + R_g Tested
- Reliable and Rugged
- Lower Q_g and Q_{gd} for high-speed switching
- Lower $R_{DS(ON)}$ to Minimize Conduction Losses
- Lead Free and Green Devices Available (RoHS Compliant)

Applications

- For E-cigrate Application.
- For Auto Model Airplane.
- Synchronous Rectifier for Server.

Pin Description

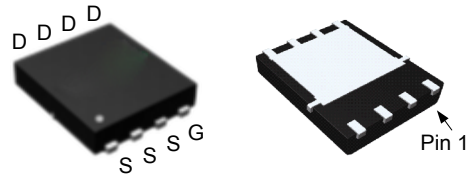

PDFN5x6-8

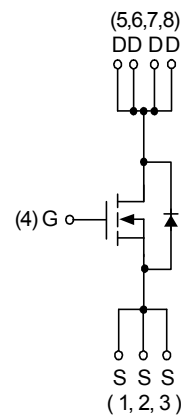

N-Channel MOSFET

Absolute Maximum Ratings ($T_A = 25^\circ\text{C}$ Unless Otherwise Noted)

Symbol	Parameter	Rating	Unit
Common Ratings			
V_{DSS}	Drain-Source Voltage	30	V
V_{GSS}	Gate-Source Voltage	± 20	
T_J	Maximum Junction Temperature	150	$^\circ\text{C}$
T_{STG}	Storage Temperature Range	-55 to 150	
I_S	Diode Continuous Forward Current	$T_C=25^\circ\text{C}$ 66	A
I_D^a	Continuous Drain Current	$T_C=25^\circ\text{C}$ 150*	
		$T_C=100^\circ\text{C}$ 150*	
I_{DM}^b	Pulsed Drain Current	$T_C=25^\circ\text{C}$ 400	
P_D	Maximum Power Dissipation	$T_C=25^\circ\text{C}$ 120	W
		$T_C=100^\circ\text{C}$ 80	
$R_{\theta JC}$	Thermal Resistance-Junction to Case	Steady State 1.7	$^\circ\text{C/W}$
$R_{\theta JA}^c$	Thermal Resistance-Junction to Ambient	$t \leq 10\text{s}$ 23	$^\circ\text{C/W}$
		Steady State 60	
I_{AS}^d	Avalanche Current, Single pulse	$L=0.1\text{mH}$ 60	A
E_{AS}^d	Avalanche Energy, Single pulse	$L=0.1\text{mH}$ 180	mJ

Note a,* : Max. continue current is limited by bonding wire.

Note b : Pulse width is limited by max. junction temperature.

Note c : $R_{\theta JA}$ steady state $t=999\text{s}$.

Note d : UIS tested and pulse width limited by maximum junction temperature 150°C (initial temperature $T_J=25^\circ\text{C}$).

Electrical Characteristics ($T_A = 25^\circ\text{C}$ unless otherwise noted)

Symbol	Parameter	Test Conditions	Min.	Typ.	Max.	Unit
Static Characteristics						
BV_{DSS}	Drain-Source Breakdown Voltage	$V_{GS}=0V, I_{DS}=250\mu A$	30	-	-	V
$BV_{DSS(t)}$	Drain-Source Breakdown Voltage (transient)	$V_{GS}=0V, I_{D(aval)}=51A$ $T_{case}=25^\circ\text{C}, t_{transient}=100ns$	34	-	-	V
I_{DSS}	Zero Gate Voltage Drain Current	$V_{DS}=24V, V_{GS}=0V$	-	-	1	μA
		$T_J=85^\circ\text{C}$	-	-	30	
$V_{GS(th)}$	Gate Threshold Voltage	$V_{DS}=V_{GS}, I_{DS}=250\mu A$	1.0	1.5	2.0	V
I_{GSS}	Gate Leakage Current	$V_{GS}=\pm 20V, V_{DS}=0V$	-	-	± 100	nA
$R_{DS(ON)}^e$	Drain-Source On-state Resistance	$V_{GS}=10V, I_{DS}=25A$	-	1.4	1.6	m Ω
		$V_{GS}=4.5V, I_{DS}=15A$	-	1.9	2.5	
G_{fs}	Forward Transconductance	$V_{DS}=5V, I_{DS}=20A$	-	30	-	S
Diode Characteristics						
V_{SD}^e	Diode Forward Voltage	$I_{SD}=25A, V_{GS}=0V$	-	0.75	1.1	V
t_{rr}	Reverse Recovery Time	$I_{SD}=25A, di_{SD}/dt=100A/\mu s$ $V_{DS}=15V$	-	55.2	-	ns
t_a	Charge Time		-	25.5	-	
t_b	Discharge Time		-	30	-	
Q_{rr}	Reverse Recovery Charge		-	52.5	-	
Dynamic Characteristics						
R_G	Gate Resistance	$V_{GS}=0V, V_{DS}=0V, F=1MHz$	-	1	2.2	Ω
C_{iss}	Input Capacitance	$V_{GS}=0V,$ $V_{DS}=15V,$ Frequency=1.0MHz	-	2810	-	pF
C_{oss}	Output Capacitance		-	759	-	
C_{riss}	Reverse Transfer Capacitance		-	26	-	
$t_{d(ON)}$	Turn-on Delay Time	$V_{DD}=15V, R_L=15\Omega,$ $I_{DS}=1A, V_{GEN}=10V,$ $R_G=1\Omega$	-	10	-	ns
t_r	Turn-on Rise Time		-	11	-	
$t_{d(OFF)}$	Turn-off Delay Time		-	48	-	
t_f	Turn-off Fall Time		-	13	-	
Gate Charge Characteristics						
Q_g	Total Gate Charge	$V_{DS}=15V, V_{GS}=10V,$ $I_{DS}=25A$	-	50	63	nC
Q_g	Total Gate Charge	$V_{DS}=15V, V_{GS}=4.5V,$ $I_{DS}=25A$	-	22	-	
Q_{gth}	Threshold Gate Charge		-	4.5	-	
Q_{gs}	Gate-Source Charge		-	6.5	-	
Q_{gd}	Gate-Drain Charge		-	11	-	

 Note e : Pulse test ; pulse width $\leq 300\mu s$, duty cycle $\leq 2\%$.

Typical Operating Characteristics

Power Dissipation

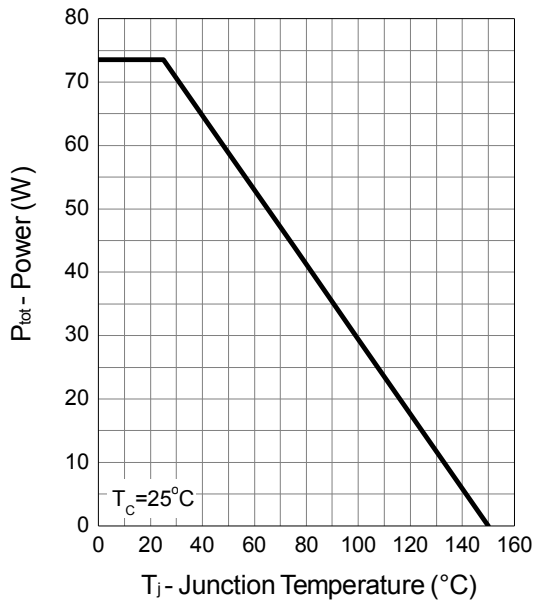

Drain Current

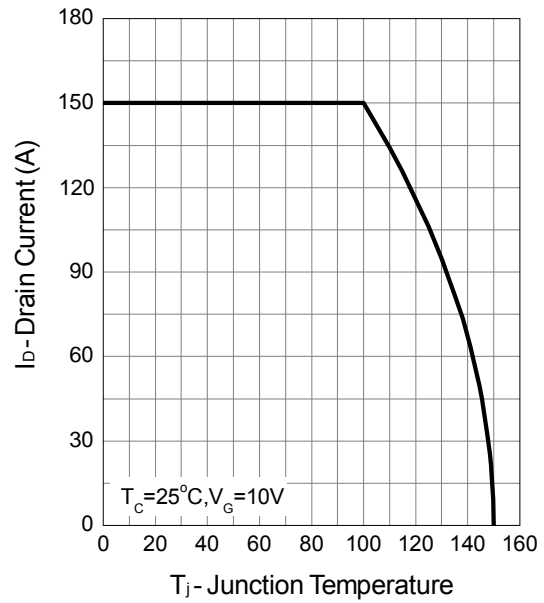

Safe Operation Area

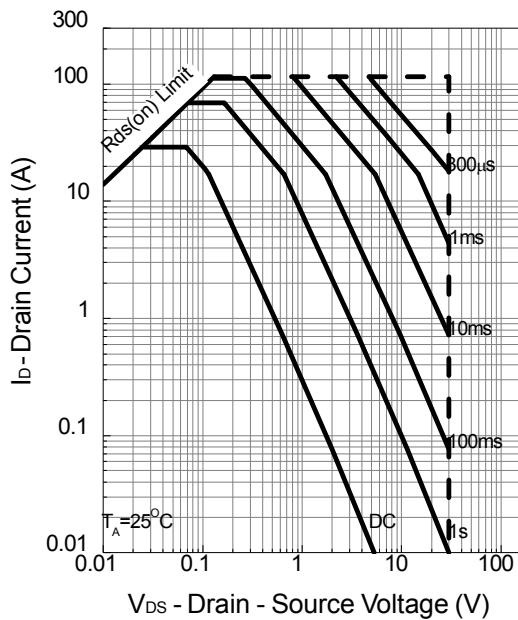

Thermal Transient Impedance

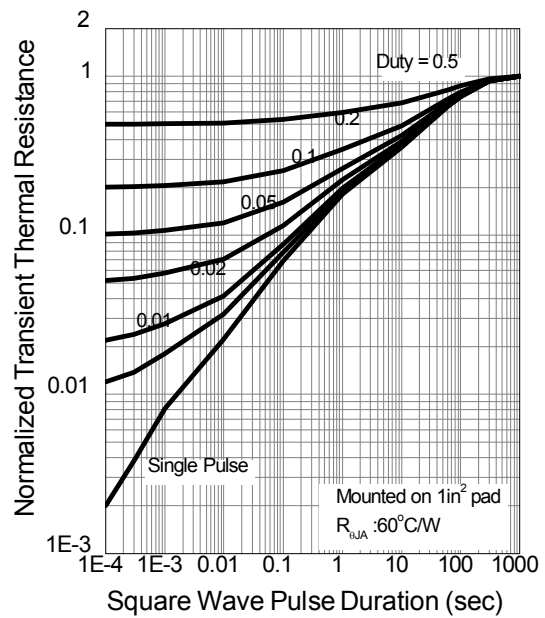

Typical Operating Characteristics (Cont.)

Output Characteristics

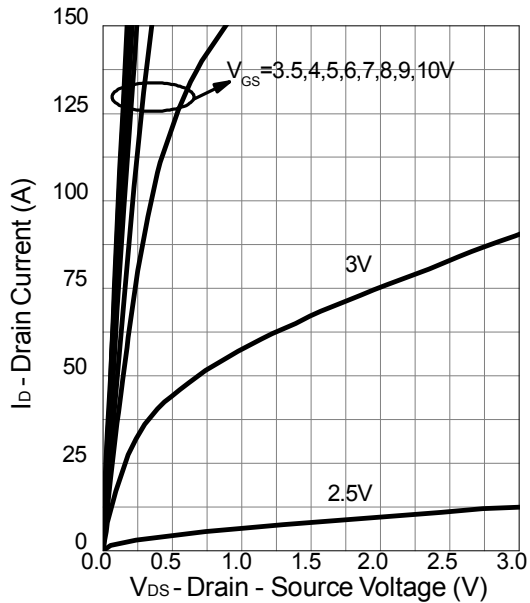

Drain-Source On Resistance

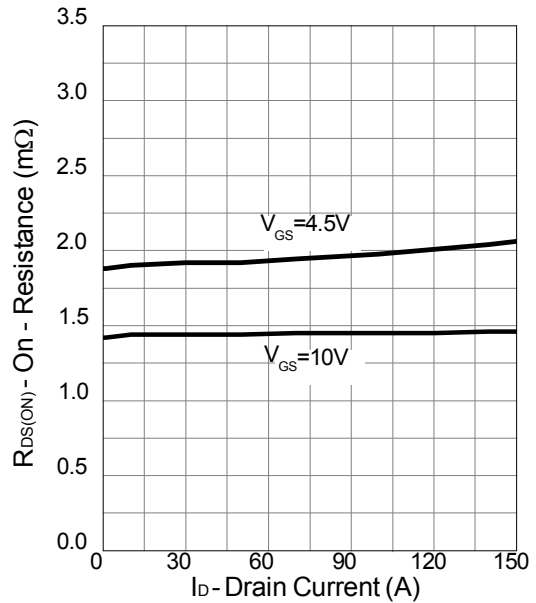

Gate-Source On Resistance

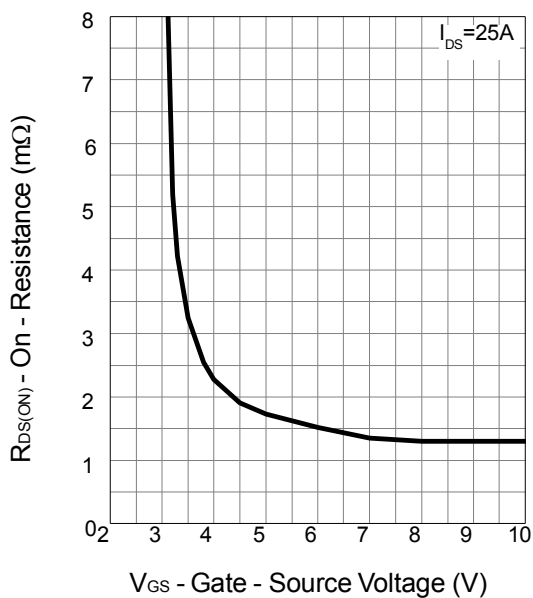

Gate Threshold Voltage

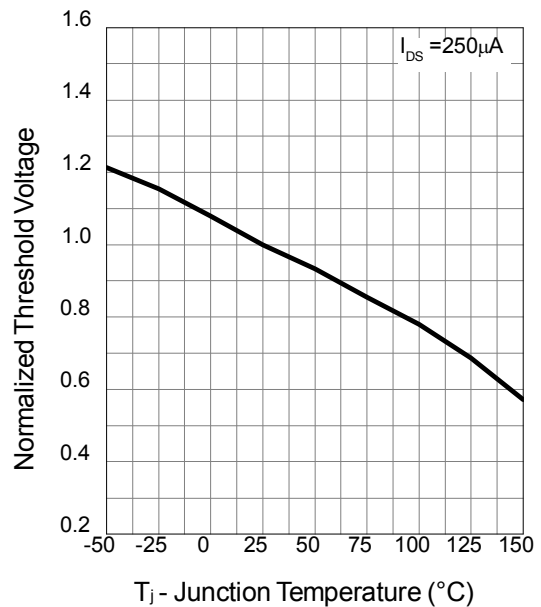

Typical Operating Characteristics (Cont.)

Drain-Source On Resistance

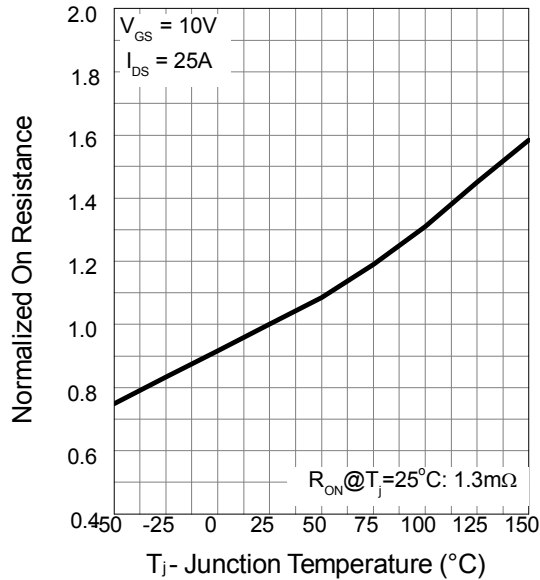

Source-Drain Diode Forward

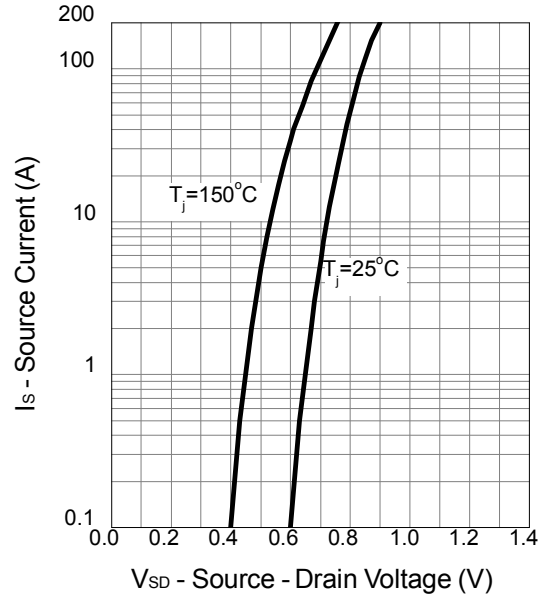

Capacitance

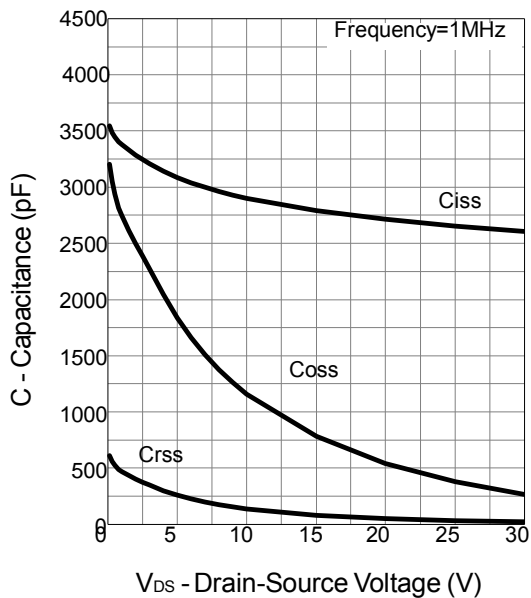

Gate Charge

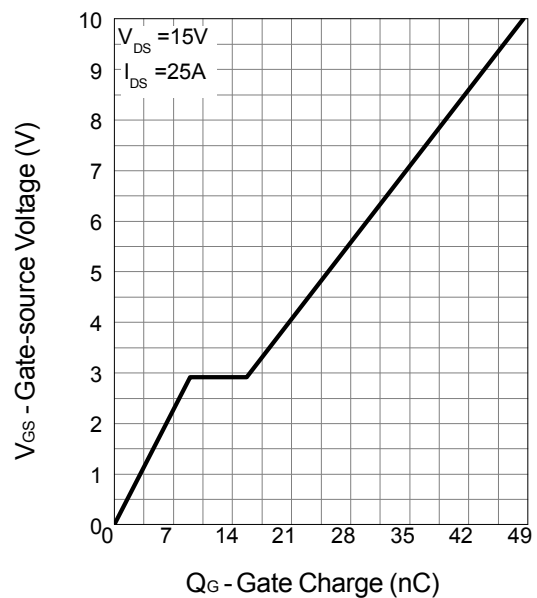

Avalanche Test Circuit and Waveforms

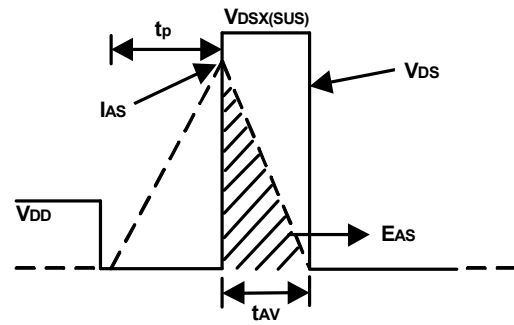
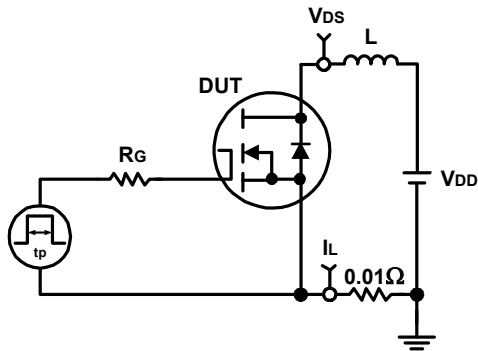

Switching Time Test Circuit and Waveforms

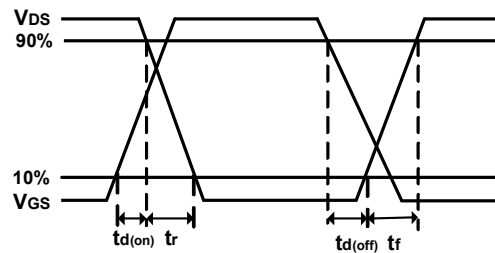
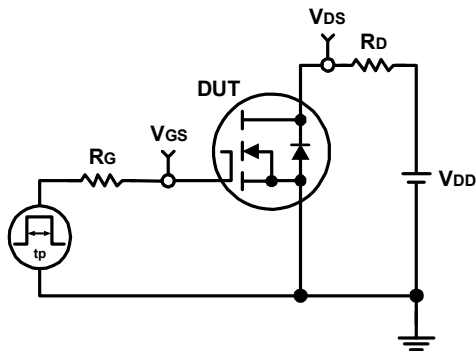

Package Information

PDFN5x6-8

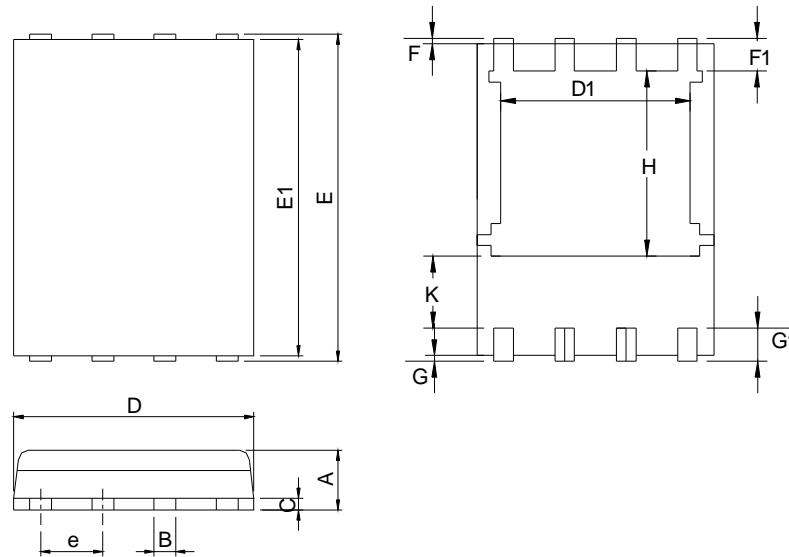

DIMENSIONS	PDFN5x6-8			
	MILLIMETERS		INCHES	
	MIN.	MAX.	MIN.	MAX.
A	0.90	1.20	0.035	0.047
B	0.3	0.51	0.012	0.020
C	0.19	0.25	0.007	0.010
D	4.80	5.30	0.189	0.209
D1	4.00	4.40	0.157	0.173
E	5.90	6.20	0.232	0.244
E1	5.50	5.80	0.217	0.228
e	1.27 BSC		0.050 BSC	
F	0.05	0.30	0.002	0.012
F1	0.35	0.75	0.014	0.030
G	0.05	0.30	0.002	0.012
G1	0.35	0.75	0.014	0.030
H	3.34	3.9	0.131	0.154
K	0.762	-	0.03	-

RECOMMENDED LAND PATTERN

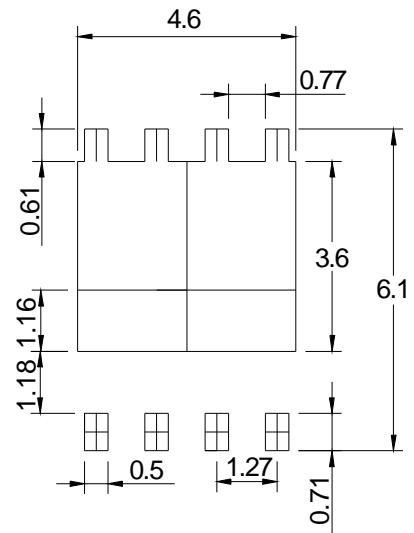

UNIT: mm

Note : 1.Dimension D, D1,D2 and E1 do not include mold flash or protrusions.
Mold flash or protrusions shall not exceed 10 mil.