

Features

- 20V/80A
 $R_{DS(ON)}=3.5m\Omega(\text{typ.})@V_{GS}=4.5V$
 $R_{DS(ON)}=4.5m\Omega(\text{typ.})@V_{GS}=2.5V$
- 100% UIS + R_g Tested
- Reliable and Rugged
- Lead Free and Green Devices Available
 (RoHS Compliant)

Applications

- Power Management in Notebook Computer, Portable Equipment and Battery Powered Systems

Pin Description

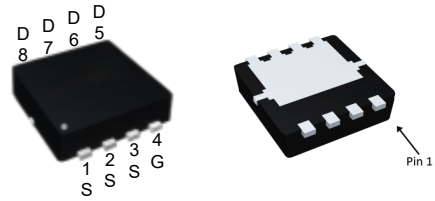

PDFN3.3*3.3-8L

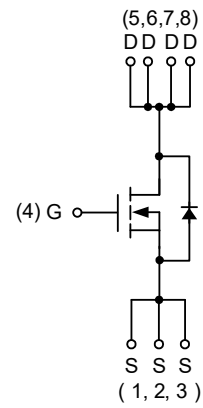

N-Channel MOSFET

Absolute Maximum Ratings ($T_A=25^\circ\text{C}$ Unless Otherwise Noted)

Symbol	Parameter	Rating	Unit
Common Ratings			
V_{DSS}	Drain-Source Voltage	20	V
V_{GSS}	Gate-Source Voltage	± 12	
T_J	Maximum Junction Temperature	150	$^\circ\text{C}$
T_{STG}	Storage Temperature Range	-55 to 150	
I_S	Diode Continuous Forward Current	$T_C=25^\circ\text{C}$ 80	A
I_D	Continuous Drain Current	$T_C=25^\circ\text{C}$ 80	A
		$T_C=100^\circ\text{C}$ 60	
I_{DM}^b	Pulsed Drain Current	$T_C=25^\circ\text{C}$ 240	
P_D	Maximum Power Dissipation	$T_C=25^\circ\text{C}$ 38	W
		$T_C=100^\circ\text{C}$ 15	
$R_{\theta JC}$	Thermal Resistance-Junction to Case	Steady State 3.3	$^\circ\text{C/W}$
$R_{\theta JA}^c$	Thermal Resistance-Junction to Ambient	$t \leq 10\text{s}$ 28	$^\circ\text{C/W}$
		Steady State 80	
I_{AS}^d	Avalanche Current, Single pulse	$L=0.1\text{mH}$ 26	A
E_{AS}^d	Avalanche Energy, Single pulse	$L=0.1\text{mH}$ 33.8	mJ

Note a : Maximum continuous current is limited by bonding wire.

Note b : Pulse width limited by maximum junction temperature.

Note c : Surface mounted on 1in^2 pad area, steady state $t = 999\text{s}$.

Note d : UIS tested and pulse width limited by maximum junction temperature (initial temperature $T_J=25^\circ\text{C}$).

Electrical Characteristics ($T_A = 25^\circ\text{C}$ unless otherwise noted)

Symbol	Parameter	Test Conditions	Min.	Typ.	Max.	Unit
Static Characteristics						
BV_{DSS}	Drain-Source Breakdown Voltage	$V_{GS}=0V, I_{DS}=250\mu A$	20	-	-	V
I_{DSS}	Zero Gate Voltage Drain Current	$V_{DS}=16V, V_{GS}=0V$ $T_J=85^\circ\text{C}$	-	-	1 30	μA
$V_{GS(th)}$	Gate Threshold Voltage	$V_{DS}=V_{GS}, I_{DS}=250\mu A$	0.5	0.75	1	V
I_{GSS}	Gate Leakage Current	$V_{GS}=\pm 20V, V_{DS}=0V$	-	-	± 100	nA
$R_{DS(ON)}^e$	Drain-Source On-state Resistance	$V_{GS}=4.5V, I_{DS}=12A$ $V_{GS}=2.5V, I_{DS}=7.2A$	-	3.5 4.5	4.4 6.1	$m\Omega$
Gfs	Forward Transconductance	$V_{DS}=5V, I_{DS}=7.2A$	-	22	-	S
Diode Characteristics						
V_{SD}^e	Diode Forward Voltage	$I_{SD}=10A, V_{GS}=0V$	-	0.7	1.1	V
t_{rr}	Reverse Recovery Time	$I_{SD}=12A, di_{SD}/dt=100A/\mu s$	-	20	-	ns
t_a	Charge Time		-	11	-	
t_b	Discharge Time		-	9	-	
Q_{rr}	Reverse Recovery Charge		-	10	-	nC
Dynamic Characteristics^f						
R_G	Gate Resistance	$V_{GS}=0V, V_{DS}=0V, F=1\text{MHz}$	-	2.1	-	Ω
C_{iss}	Input Capacitance	$V_{GS}=0V,$ $V_{DS}=10V,$ Frequency=1.0MHz	-	2440	3172	pF
C_{oss}	Output Capacitance		-	380	-	
C_{rss}	Reverse Transfer Capacitance		-	270	-	
$t_{d(ON)}$	Turn-on Delay Time	$V_{DD}=10V, R_L=10\Omega,$ $I_{DS}=1A, V_{GEN}=4.5V,$ $R_G=6\Omega$	-	13	24	ns
t_r	Turn-on Rise Time		-	13.2	24	
$t_{d(OFF)}$	Turn-off Delay Time		-	93	168	
t_f	Turn-off Fall Time		-	51	92	
Gate Charge Characteristics^f						
Q_g	Total Gate Charge	$V_{DS}=10V, V_{GS}=4.5V,$ $I_{DS}=12A$	-	25	-	nC
Q_{gth}	Threshold Gate Charge		-	1.8	2.3	
Q_{gs}	Gate-Source Charge		-	3.7	4.8	
Q_{gd}	Gate-Drain Charge		-	6.6	9.9	

 Note e : Pulse test ; pulse width $\leq 300\mu s$, duty cycle $\leq 2\%$.

Note f : Guaranteed by design, not subject to production testing.

Typical Operating Characteristics

Power Dissipation

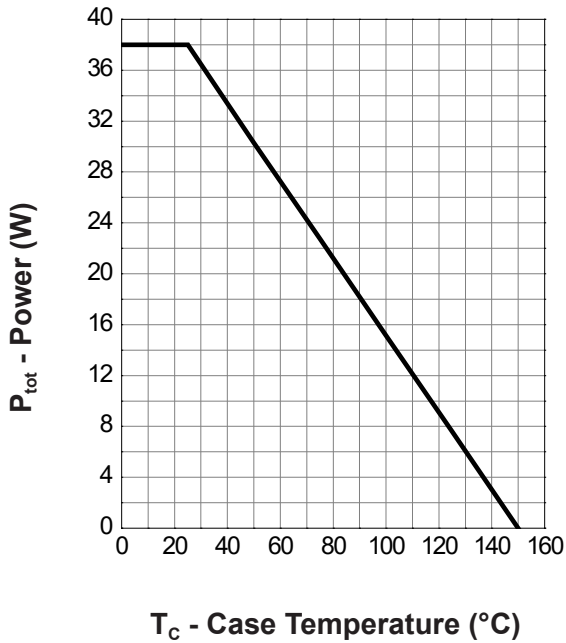

Drain Current

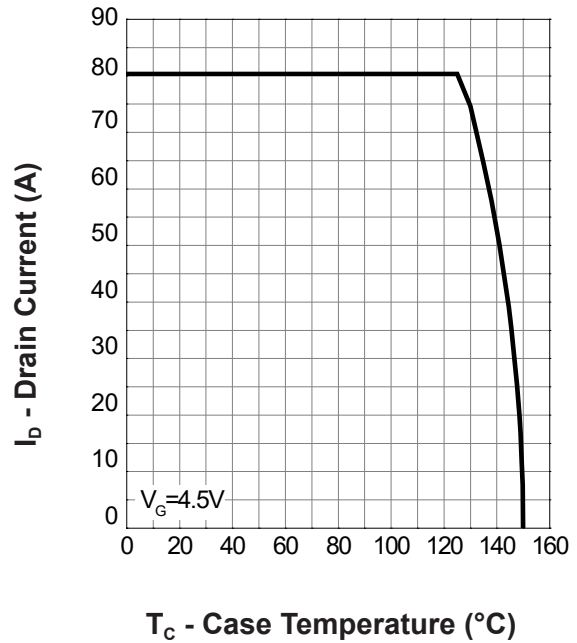

Safe Operation Area

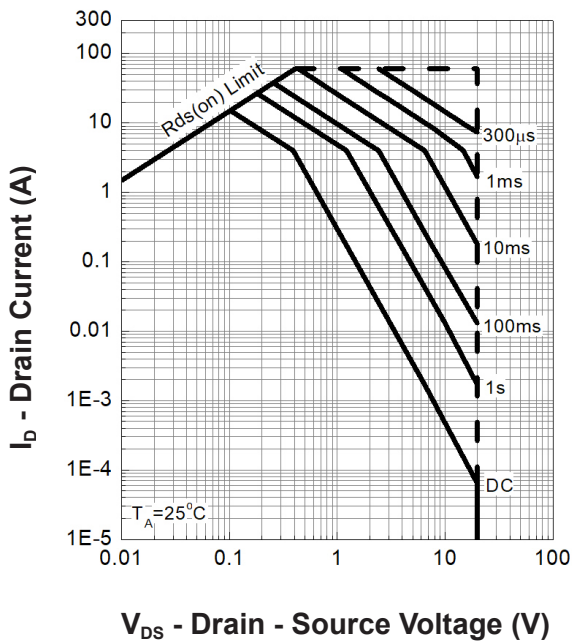

Thermal Transient Impedance

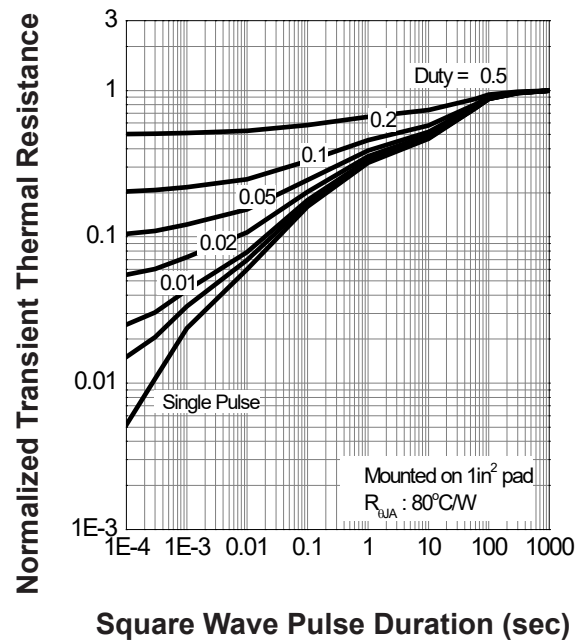

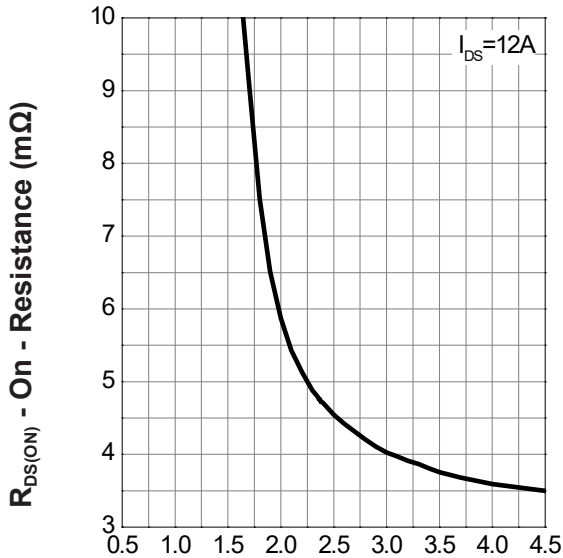
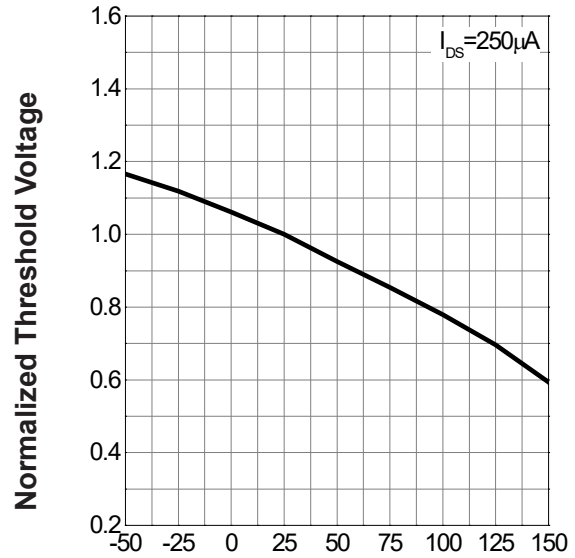
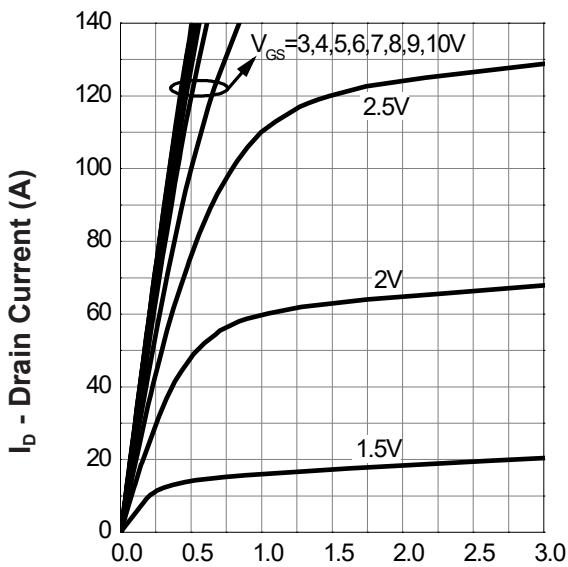
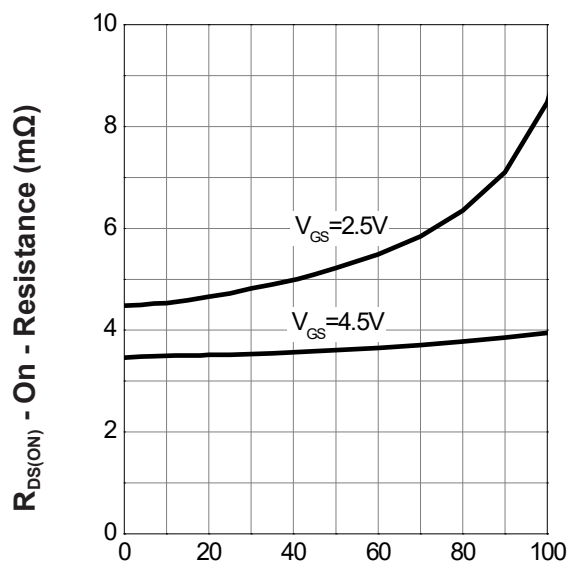
Typical Operating Characteristics(Cont.)
Gate-Source On Resistance

 V_{GS} - Gate - Source Voltage (V)
Gate Threshold Voltage

 T_J - Junction Temperature (°C)
Output Characteristics

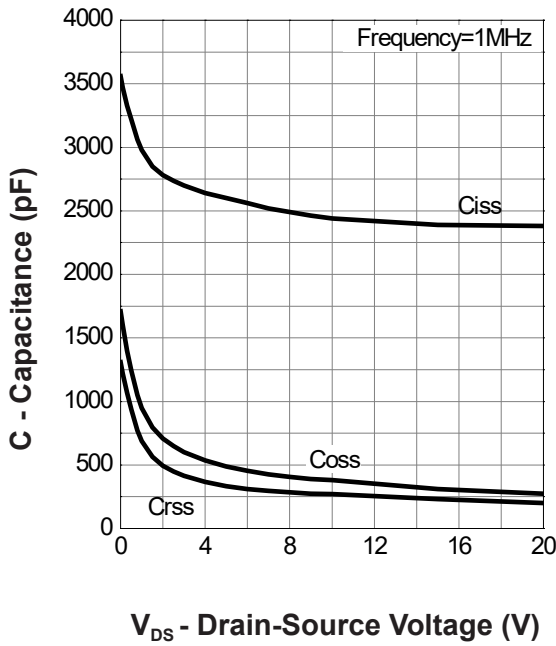
 V_{DS} - Drain - Source Voltage (V)
Drain-Source On Resistance

 I_D - Drain Current (A)

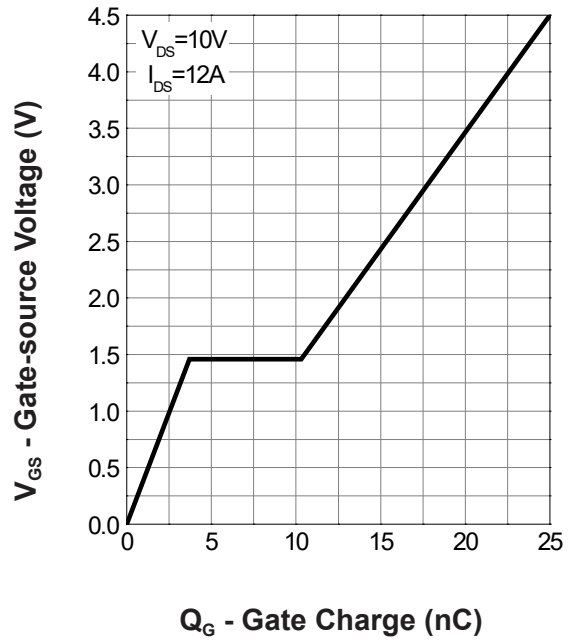
Typical Operating Characteristics(Cont.)

Capacitance



Gate Charge



Drain-Source On Resistance

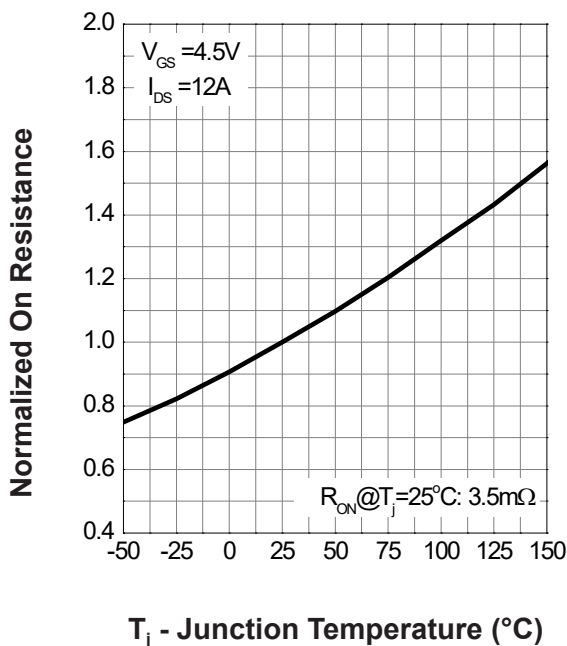

Source-Drain Diode Forward

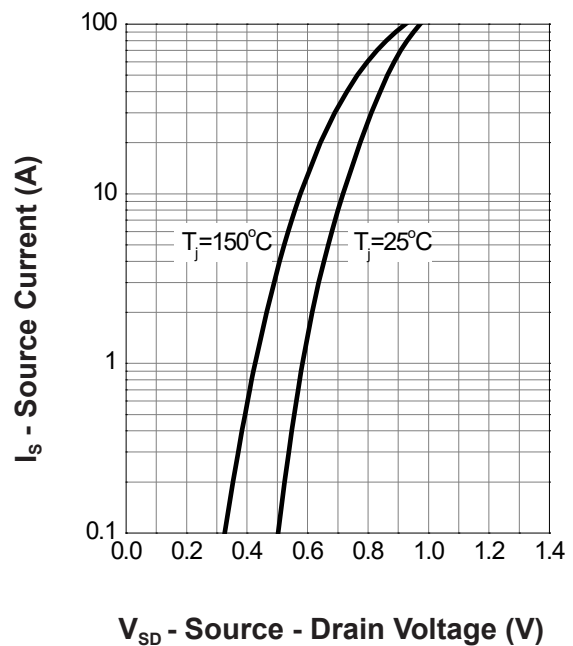

Avalanche Test Circuit and Waveforms

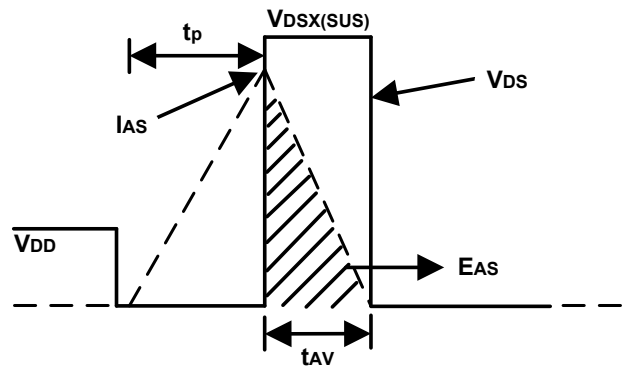
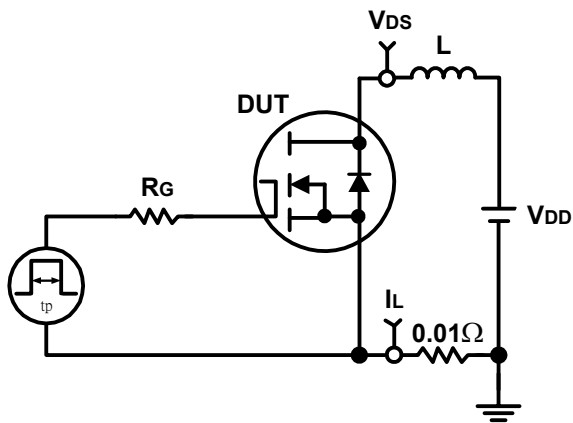

Switching Time Test Circuit and Waveforms

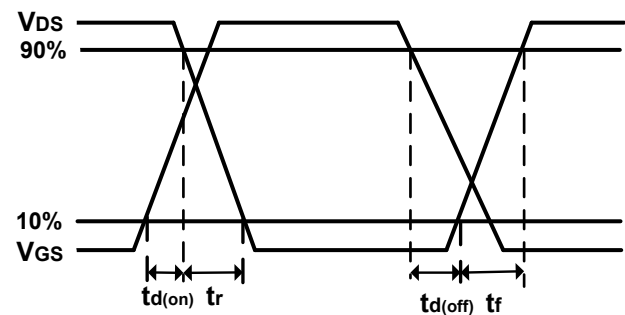
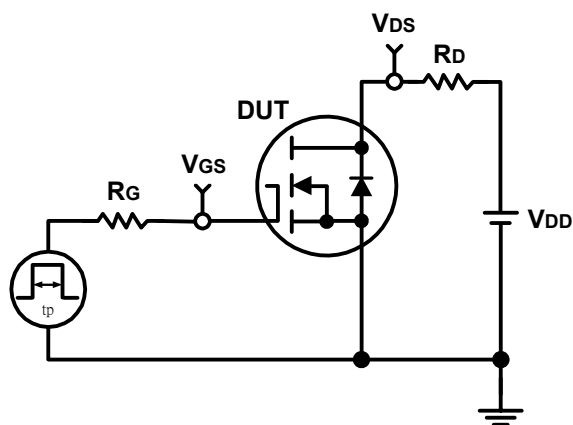

Package Information

PDFN3.3*3.3-8L

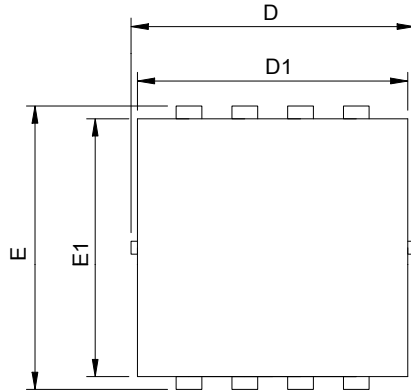
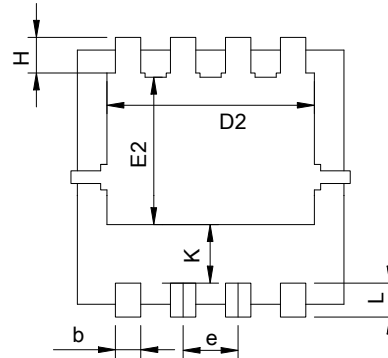
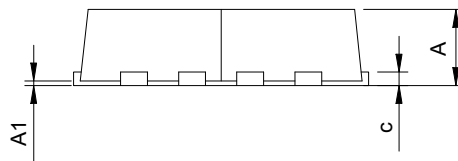
Top View

Bottom View

Side View

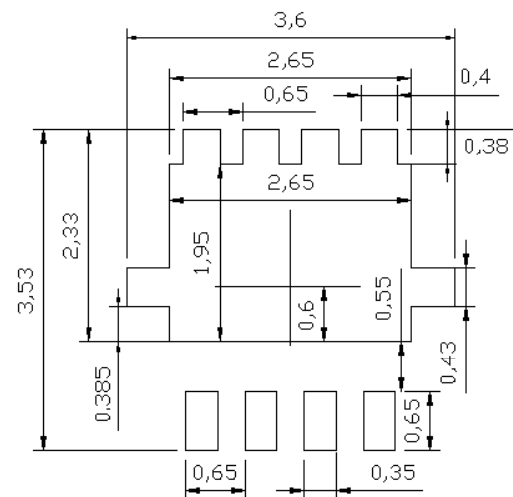
SYMBOL	PDFN3.3*3.3-8L			
	MILLIMETERS		INCHES	
	MIN.	MAX.	MIN.	MAX.
A	0.70	1.00	0.028	0.039
A1	0.00	0.05	0.000	0.002
b	0.25	0.35	0.010	0.014
c	0.10	0.25	0.004	0.010
D	3.10	3.50	0.122	0.138
D1	3.05	3.25	0.120	0.128
D2	2.35	2.59	0.093	0.102
E	3.10	3.50	0.122	0.138
E1	2.90	3.10	0.114	0.122
E2	1.64	1.98	0.065	0.078
e	0.65 BSC		0.026 BSC	
H	0.32	0.52	0.013	0.020
K	0.59	0.79	0.023	0.031
L	0.25	0.55	0.010	0.022

RECOMMENDED LAND PATTERN



UNIT: mm