

### Features

- 18V/60A,  
 $R_{DS(ON)} = 3m\Omega(\text{typ.}) @ V_{GS} = 4.5V$   
 $R_{DS(ON)} = 3.7m\Omega(\text{typ.}) @ V_{GS} = 2.5V$
- 100% UIS +  $R_g$  Tested
- Reliable and Rugged
- Lead Free and Green Devices Available (RoHS Compliant)
- ESD Protected

### Applications

- Power Management in Notebook Computer, Portable Equipment and Battery Powered Systems.

### Pin Description

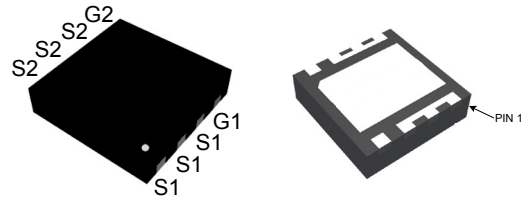

PDFN3.3\*3.3-8L

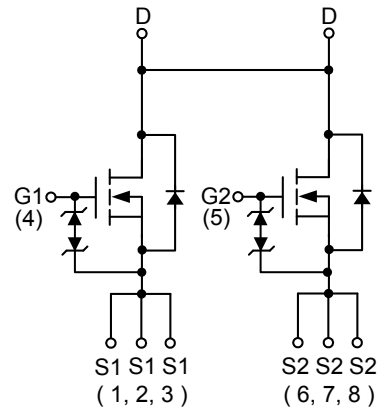

N-Channel MOSFET

**Absolute Maximum Ratings** ( $T_A = 25^\circ\text{C}$  Unless Otherwise Noted)

Symbol	Parameter	Rating	Unit
<b>Common Ratings</b> ( $T_A=25^\circ\text{C}$ Unless Otherwise Noted)			
$V_{DSS}$	Drain-Source Voltage	18	V
$V_{GSS}$	Gate-Source Voltage	$\pm 10$	
$T_J$	Maximum Junction Temperature	150	$^\circ\text{C}$
$T_{STG}$	Storage Temperature Range	-55 to 150	
$I_S$	Diode Continuous Forward Current	$T_C=25^\circ\text{C}$ 60	A
$I_D^a$	Continuous Drain Current	$T_C=25^\circ\text{C}$ 60	A
		$T_C=100^\circ\text{C}$ 48	
$I_{DM}^b$	Pulsed Drain Current	$T_C=25^\circ\text{C}$ 180	
$P_D$	Maximum Power Dissipation	$T_C=25^\circ\text{C}$ 35	W
		$T_C=100^\circ\text{C}$ 14	
$R_{\theta JC}$	Thermal Resistance-Junction to Case	Steady State 3.5	$^\circ\text{C/W}$
$R_{\theta JA}^d$	Thermal Resistance-Junction to Ambient	Steady State 78	$^\circ\text{C/W}$
$I_{AS}^e$	Avalanche Current, Single pulse (L=0.1mH)	45	A
$E_{AS}^e$	Avalanche Energy, Single pulse (L=0.1mH)	100	mJ

Note a: Package is limited by 50A

Note b: Pulse width limited by max. junction temperature.

Note c:  $R_{\theta JA}$  steady state=999s.

Note d:  $R_{\theta JA}$  steady state=999s.  $R_{\theta JA}$  is measured with the device mounted on 1in2, Fr-4 board with 2oz.Copper.

Note e: UIS tested and pulse width limited by maximum junction temperature  $150^\circ\text{C}$  (initial temperature  $T_J=25^\circ\text{C}$ ).

**Electrical Characteristics** ( $T_A = 25^\circ\text{C}$  Unless Otherwise Noted)

Symbol	Parameter	Test Conditions	Min.	Typ.	Max.	Unit
<b>Static Characteristics</b>						
$BV_{DSS}$	Drain-Source Breakdown Voltage	$V_{GS}=0V, I_{DS}=250\mu A$	18	-	-	V
$I_{DSS}$	Zero Gate Voltage Drain Current	$V_{DS}=14.4V, V_{GS}=0V$ $T_J=85^\circ\text{C}$	-	-	1	$\mu A$
			-	-	30	
$V_{GS(th)}$	Gate Threshold Voltage	$V_{DS}=V_{GS}, I_{DS}=250\mu A$	0.5	0.7	1	V
$I_{GSS}$	Gate Leakage Current	$V_{GS}=\pm 10V, V_{DS}=0V$	-	-	$\pm 10$	$\mu A$
$R_{DS(ON)}^g$	Drain-Source On-state Resistance	$V_{GS}=4.5V, I_{DS}=13.5A$	-	3	3.4	m $\Omega$
		$V_{GS}=2.5V, I_{DS}=10A$	-	3.7	4.3	
$G_{fs}$	Forward Transconductance	$V_{DS}=5V, I_{DS}=10A$	-	34	-	S
<b>Diode Characteristics</b>						
$V_{SD}^d$	Diode Forward Voltage	$I_{SD}=2A, V_{GS}=0V$	-	0.7	1.1	V
$t_{rr}$	Reverse Recovery Time	$I_{SD}=13.5A,$	-	18	-	ns
$Q_{rr}$	Reverse Recovery Charge	$di_{SD}/dt=100A/\mu s$	-	6.2	-	nC
<b>Dynamic Characteristics</b> <sup>g</sup>						
$R_G$	Gate Resistance	$V_{GS}=0V, V_{DS}=0V, f=1\text{MHz}$	--	2	3.6	$\Omega$
$C_{iss}$	Input Capacitance	$V_{GS}=0V,$ $V_{DS}=10V,$ Frequency=1.0MHz	-	3775	4910	pF
$C_{oss}$	Output Capacitance		-	730	-	
$C_{rss}$	Reverse Transfer Capacitance		-	525	-	
$t_{d(ON)}$	Turn-on Delay Time	$V_{DD}=10V, R_L=10\Omega,$ $I_{DS}=1A, V_{GEN}=10V,$ $R_G=6\Omega$	-	14	26	ns
$t_r$	Turn-on Rise Time		-	14.5	27	
$t_{d(OFF)}$	Turn-off Delay Time		-	130	234	
$t_f$	Turn-off Fall Time		-	70	126	
<b>Gate Charge Characteristics</b> <sup>g</sup>						
$Q_g$	Total Gate Charge	$V_{DS}=10V, V_{GS}=4.5V,$ $I_{DS}=13.5A$	-	35	50	nC
$Q_{gs}$	Gate-Source Charge		-	4.7	-	
$Q_{gd}$	Gate-Drain Charge		-	11.5	-	

 Note f: Pulse test; pulse width $\leq 300\mu s$ , duty cycle $\leq 2\%$ .

Note g: Guaranteed by design, not subject to production testing.

## Typical Operating Characteristics

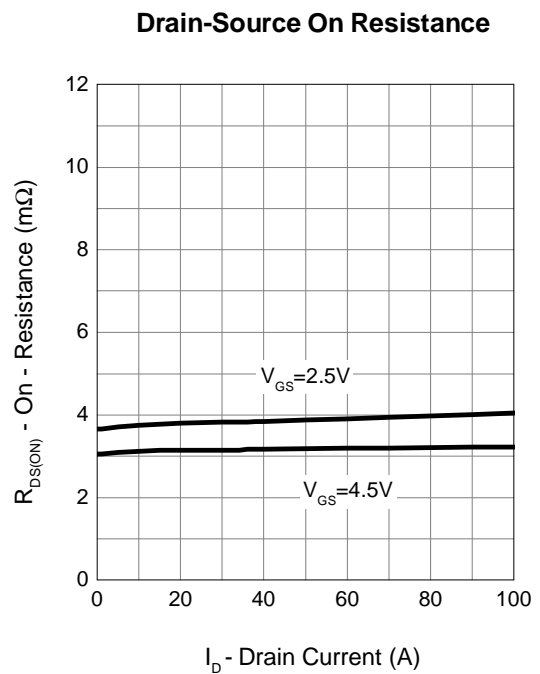
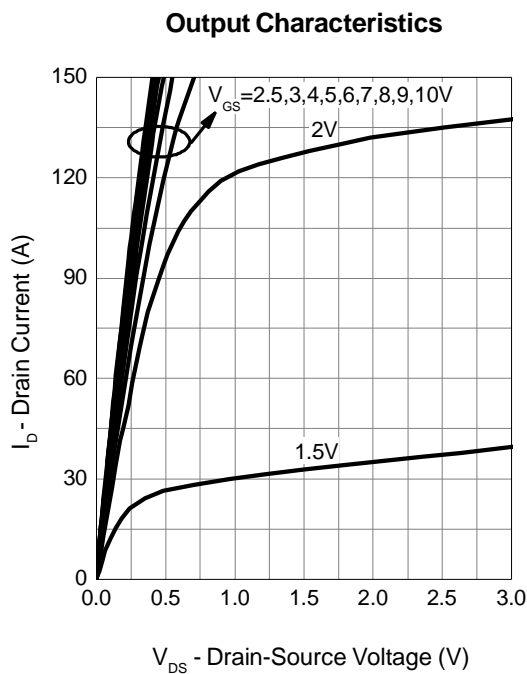
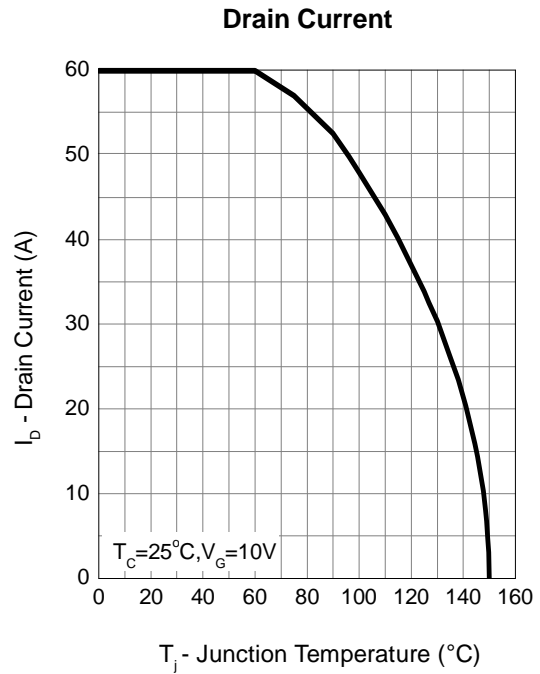
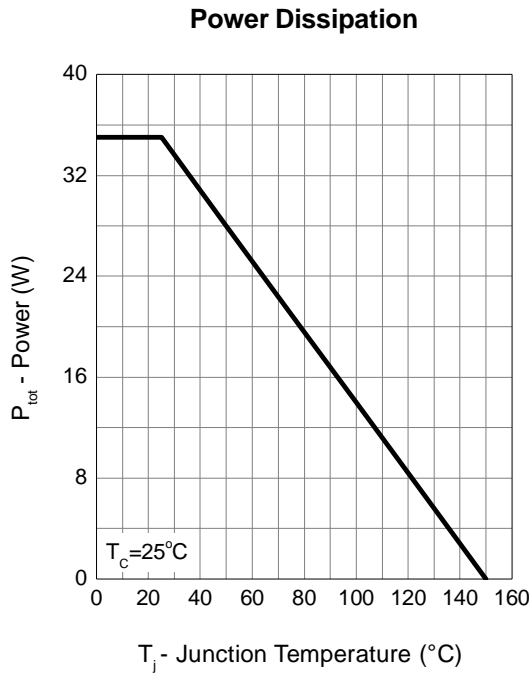

### Typical Operating Characteristics (Cont.)

**Safe Operation Area**

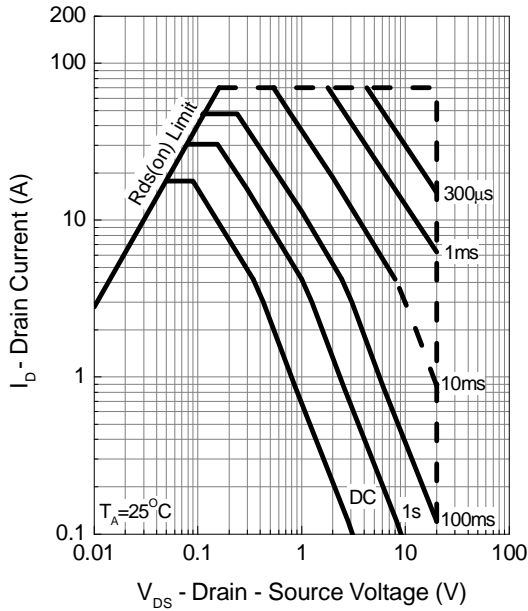

**Thermal Transient Impedance**

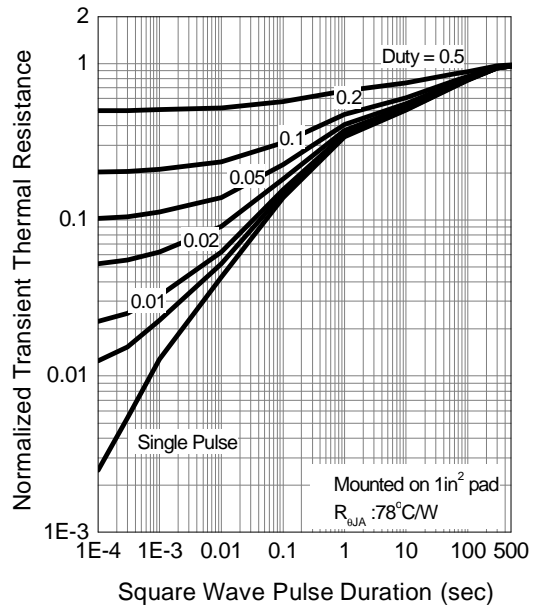

**Capacitance**

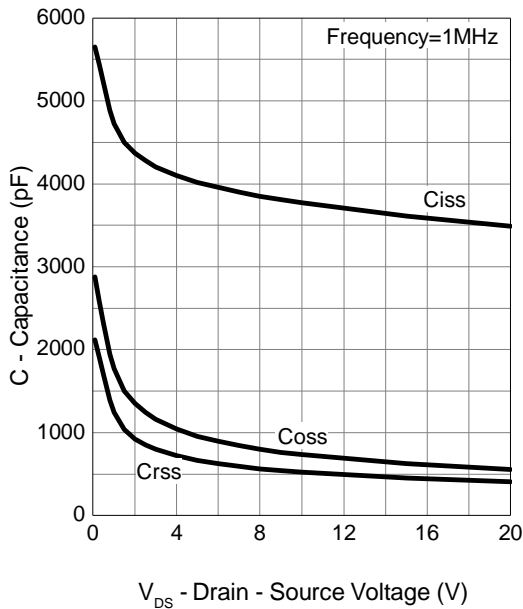

**Gate Charge**

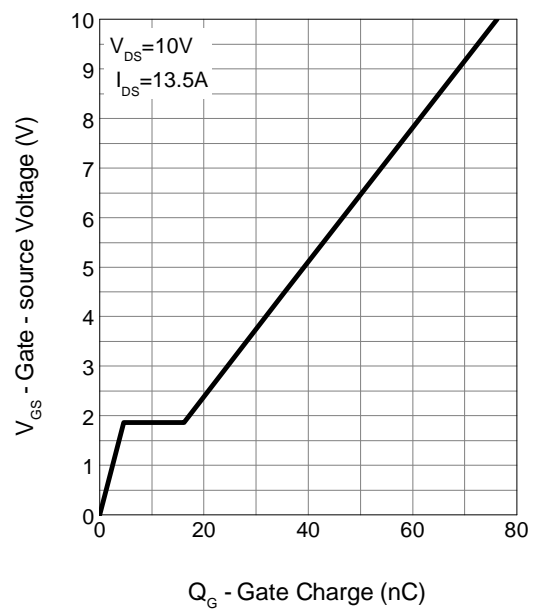

## Typical Operating Characteristics (Cont.)

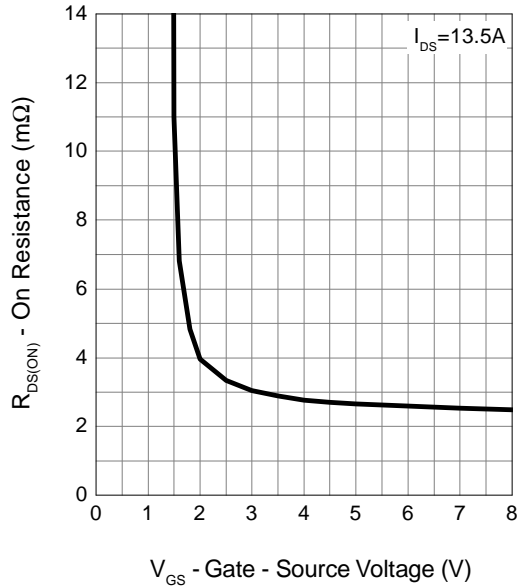
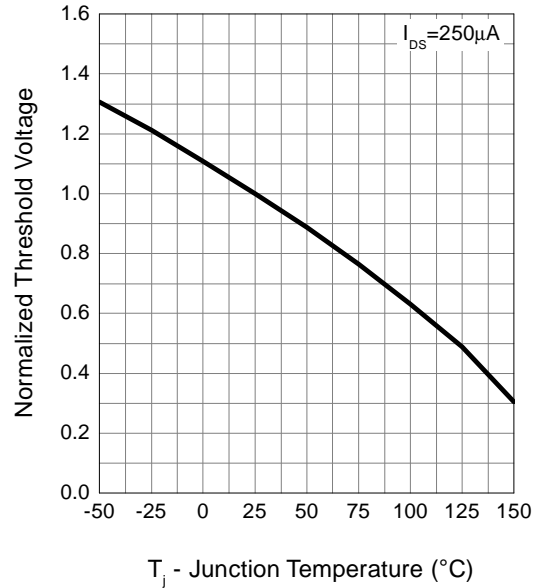
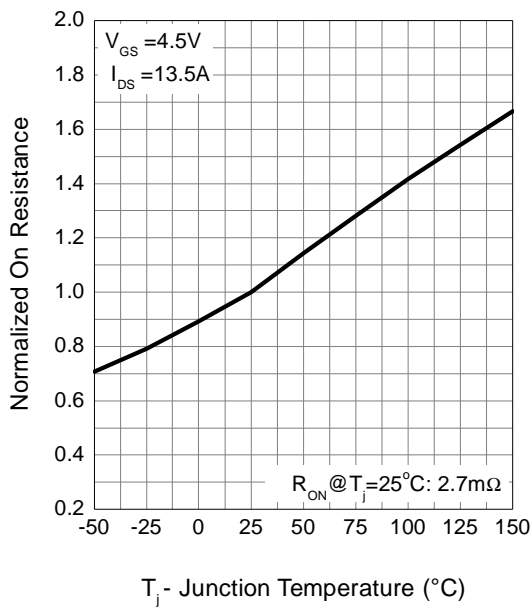
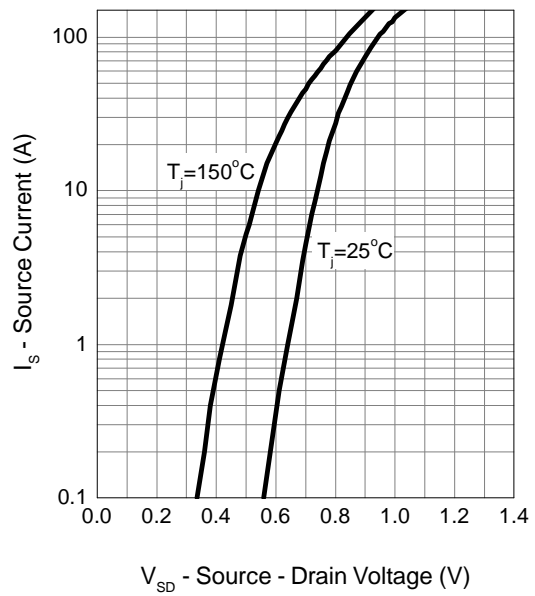
**Gate-Source On Resistance**

**Gate Threshold Voltage**

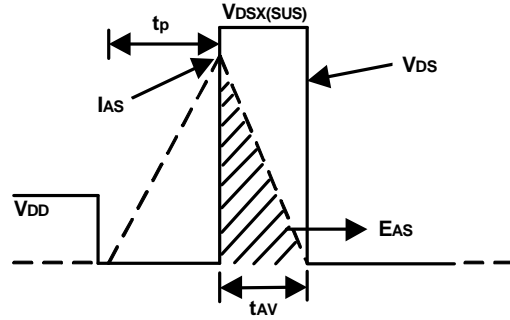
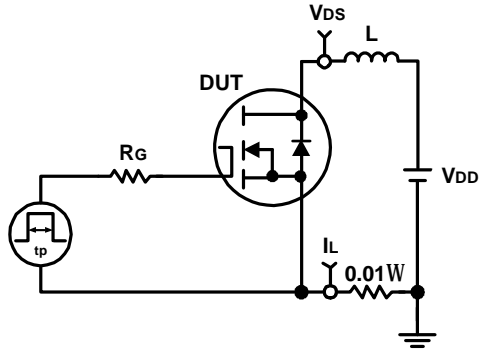
**Drain-Source On Resistance**

**Source-Drain Diode Forward**

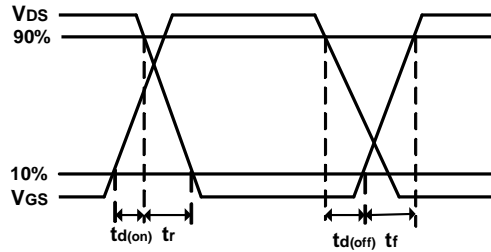
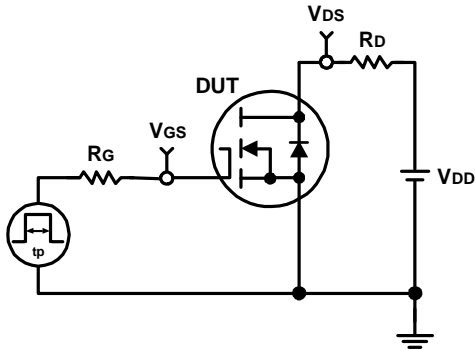
### Avalanche Test Circuit and Waveforms



### Switching Time Test Circuit and Waveforms



### Package Information

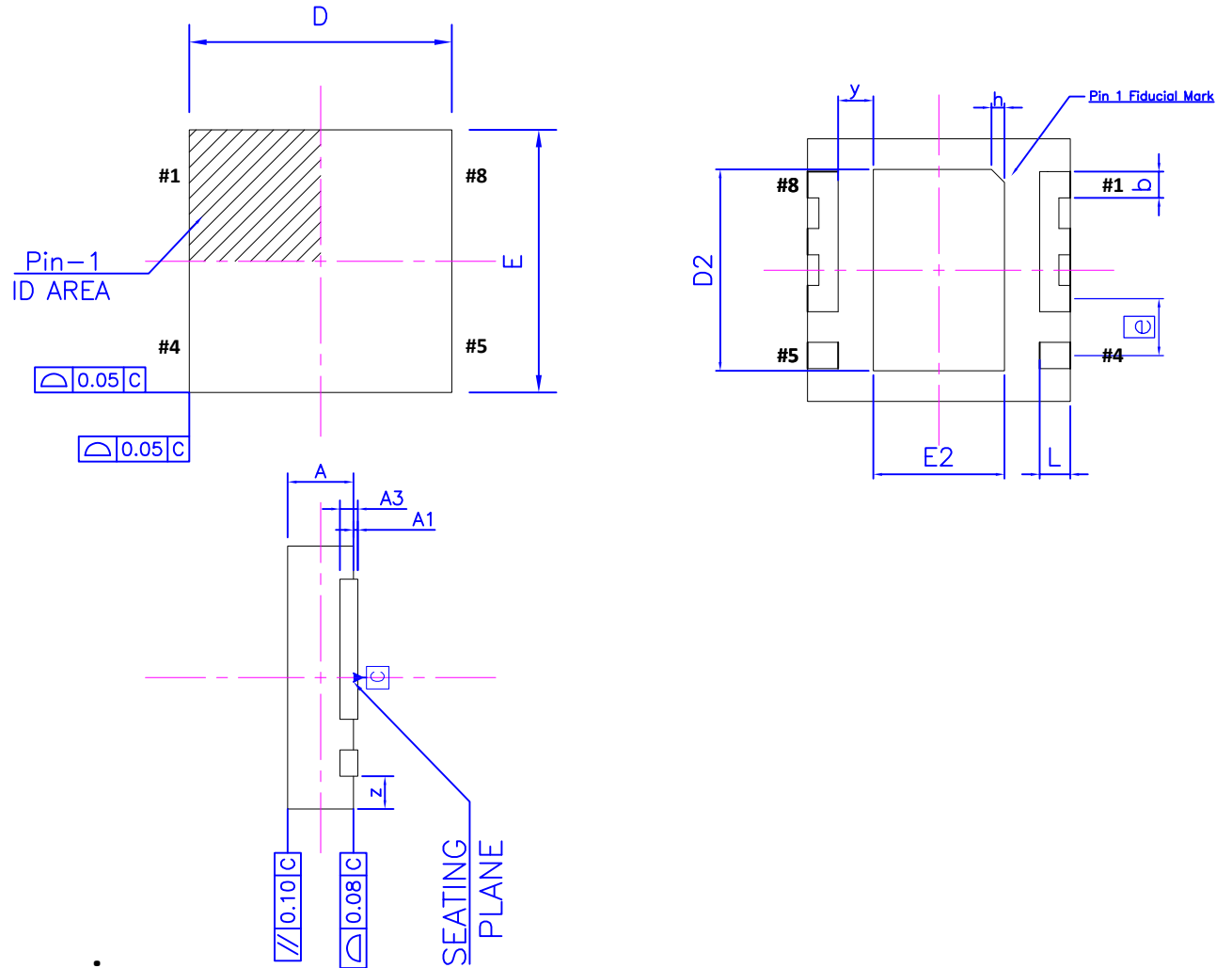

### Dimensions

Unit	D	E	D2	E2	A	A1	A3	b	e	h	L	y	z
mm	3.07 (3.00) 2.95	3.07 (3.00) 2.95	2.35 (2.30) 2.25	1.60 (1.50) 1.40	0.80 (0.75) 0.70	0.05 (0.02) 0.00	0.203 REF	0.35 (0.30) 0.25	0.65 BSC	0.15 REF	0.45 (0.35) 0.25	0.400 REF	0.375 REF