

Features

- 30V/35A,
 $R_{DS(ON)} = 16m\Omega$ (typ.) @ $V_{GS} = 10V$
 $R_{DS(ON)} = 19m\Omega$ (typ.) @ $V_{GS} = 4.5V$
- Reliable and Rugged
- Lead Free and Green Devices Available (RoHS Compliant)

Applications

- Power Management in Desktop Computer or DC/DC Converters.

Pin Description

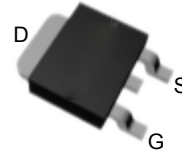

Top View of TO-252-2

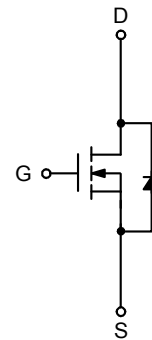

N-Channel MOSFET

Absolute Maximum Ratings ($T_A = 25^\circ\text{C}$ Unless Otherwise Noted)

Symbol	Parameter	Rating	Unit
Common Ratings ($T_A=25^\circ\text{C}$ Unless Otherwise Noted)			
V_{DSS}	Drain-Source Voltage	30	V
V_{GSS}	Gate-Source Voltage	± 20	
T_J	Maximum Junction Temperature	150	$^\circ\text{C}$
T_{STG}	Storage Temperature Range	-55 to 150	
I_S	Diode Continuous Forward Current	$T_C=25^\circ\text{C}$ 35	A
I_D	Continuous Drain Current	$T_C=25^\circ\text{C}$ 35	
		$T_C=100^\circ\text{C}$ 14	
I_{DM}^a	Pulsed Drain Current	$T_C=25^\circ\text{C}$ 105	
P_D	Maximum Power Dissipation	$T_C=25^\circ\text{C}$ 35.7	W
		$T_C=100^\circ\text{C}$ 14.3	
$R_{\theta JC}$	Thermal Resistance-Junction to Case	Steady State 3.5	$^\circ\text{C/W}$
I_D	Continuous Drain Current	$T_A=25^\circ\text{C}$ 12.2	A
		$T_A=70^\circ\text{C}$ 9.8	
P_D	Maximum Power Dissipation	$T_A=25^\circ\text{C}$ 3.1	W
		$T_A=70^\circ\text{C}$ 2.0	
$R_{\theta JA}$	Thermal Resistance-Junction to Ambient	$t \leq 10\text{s}$ 17	$^\circ\text{C/W}$
		Steady State 40	
I_{AS}^b	Avalanche Current, Single pulse ($L=0.1\text{mH}$)	19	A
E_{AS}^b	Avalanche Energy, Single pulse ($L=0.1\text{mH}$)	18	mJ

Note a: Pulse width limited by maximum junction temperature.

Note b: UIS tested and pulse width limited by maximum junction temperature 150°C (initial temperature $T_J=25^\circ\text{C}$).

Electrical Characteristics ($T_A = 25^\circ\text{C}$ Unless Otherwise Noted)

Symbol	Parameter	Test Conditions	Min.	Typ.	Max.	Unit
Static Characteristics						
BV_{DSS}	Drain-Source Breakdown Voltage	$V_{GS}=0V, I_{DS}=250\mu A$	30	-	-	V
I_{DSS}	Zero Gate Voltage Drain Current	$V_{DS}=24V, V_{GS}=0V$	-	-	1	μA
		$T_J=85^\circ C$	-	-	30	
$V_{GS(th)}$	Gate Threshold Voltage	$V_{DS}=V_{GS}, I_{DS}=250\mu A$	0.6	1	1.5	V
I_{GSS}	Gate Leakage Current	$V_{GS}=\pm 20V, V_{DS}=0V$	-	-	± 100	nA
$R_{DS(ON)}^c$	Drain-Source On-state Resistance	$V_{GS}=10V, I_{DS}=20A$	-	16	23	m Ω
		$T_J=125^\circ C$	-	22	-	
		$V_{GS}=4.5V, I_{DS}=10A$	-	19	25	
Gfs	Forward Transconductance	$V_{DS}=5V, I_D=15A$	-	24	-	S
Diode Characteristics						
V_{SD}^c	Diode Forward Voltage	$I_{SD}=5A, V_{GS}=0V$	-	0.79	1.1	V
t_{rr}	Reverse Recovery Time	$I_F=20A, di_{SD}/dt=100A/\mu s$	-	6	-	ns
t_a	Charge Time		-	5	-	
t_b	Discharge Time		-	11	-	
Q_{rr}	Reverse Recovery Charge		-	4.8	-	
Dynamic Characteristics^d						
R_G	Gate Resistance	$V_{GS}=0V, V_{DS}=0V, F=1MHz$	1.5	2.3	3.5	Ω
C_{iss}	Input Capacitance	$V_{GS}=0V, V_{DS}=15V, \text{Frequency}=1.0MHz$	700	870	1045	pF
C_{oss}	Output Capacitance		96	120	145	
C_{rss}	Reverse Transfer Capacitance		60	76	91	
$t_{d(ON)}$	Turn-on Delay Time	$V_{DD}=15V, R_L=15\Omega, I_{DS}=1A, V_{GEN}=10V, R_G=1\Omega$	-	12	-	ns
t_r	Turn-on Rise Time		-	11.8	-	
$t_{d(OFF)}$	Turn-off Delay Time		-	23.2	-	
t_f	Turn-off Fall Time		-	4.4	-	
Gate Charge Characteristics^d						
Q_g	Total Gate Charge	$V_{DS}=15V, V_{GS}=10V, I_{DS}=20A$	-	16	20	nC
Q_g	Total Gate Charge	$V_{DS}=15V, V_{GS}=4.5V, I_{DS}=20A$	-	7.2	-	
Q_{gth}	Threshold Gate Charge		-	1.48	-	
Q_{gs}	Gate-Source Charge		-	3	-	
Q_{gd}	Gate-Drain Charge		-	2.7	-	

 Note c: Pulse test ; pulse width $\leq 300\mu s$, duty cycle $\leq 2\%$.

Note d: Guaranteed by design, not subject to production testing.

Typical Operating Characteristics

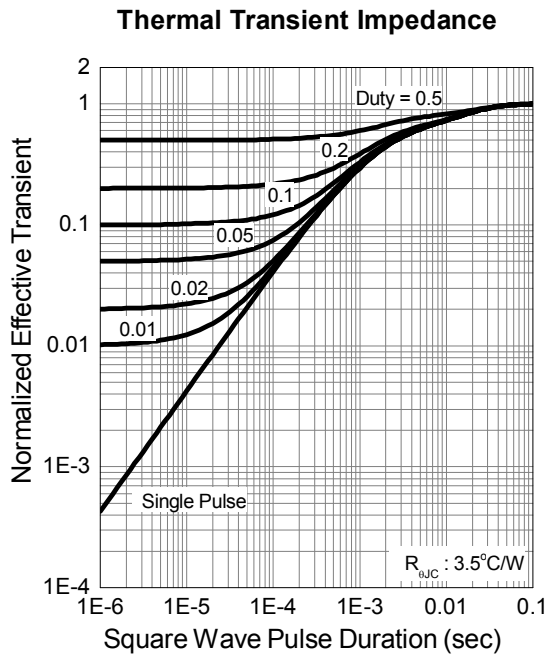
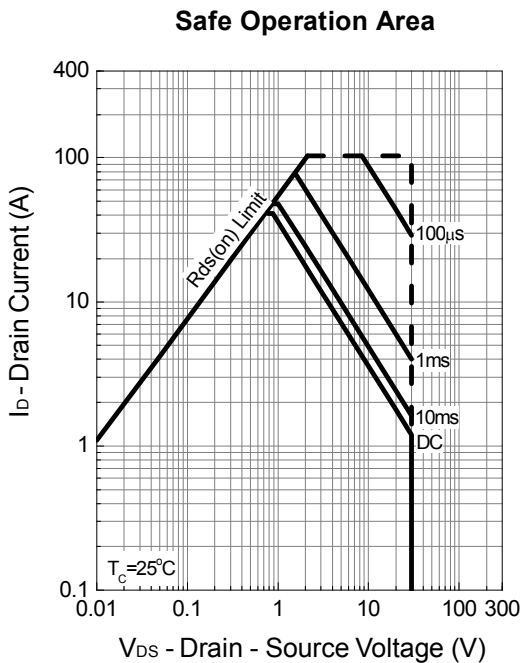
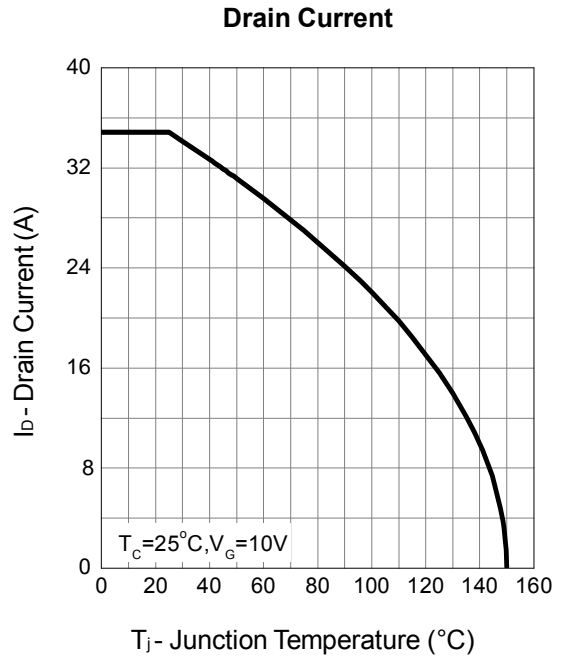
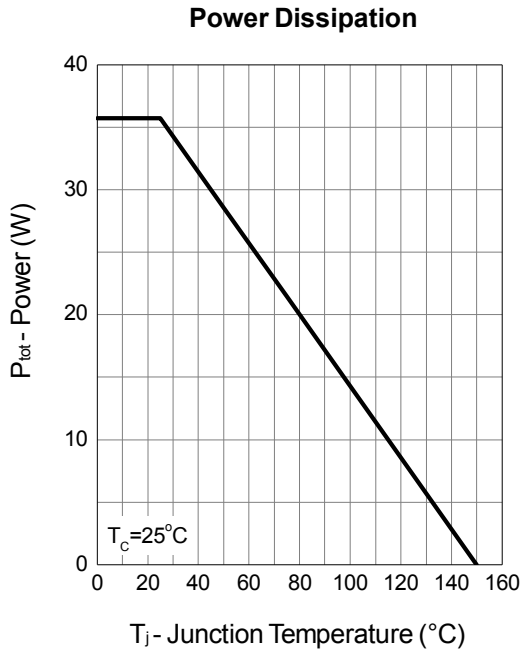

Typical Operating Characteristics (Cont.)

Output Characteristics

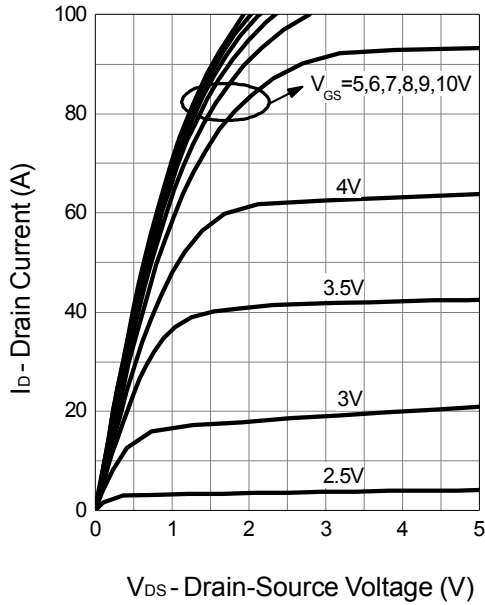

Drain-Source On Resistance

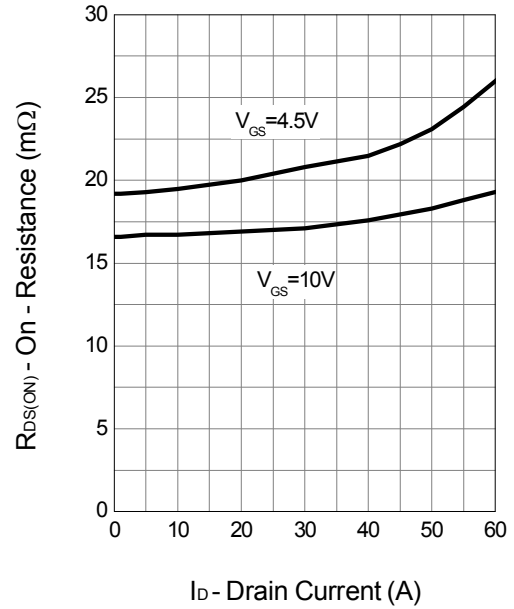

Gate-Source On Resistance

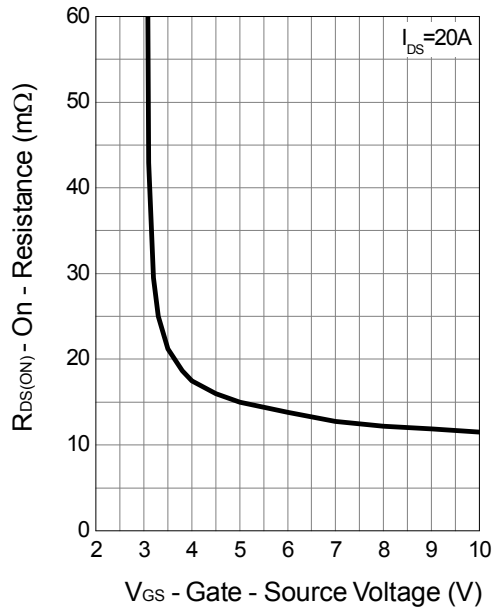

Gate Threshold Voltage

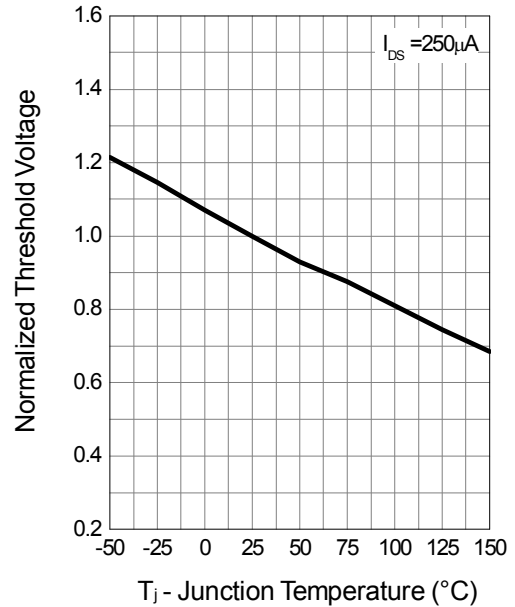

Typical Operating Characteristics (Cont.)

Drain-Source On Resistance

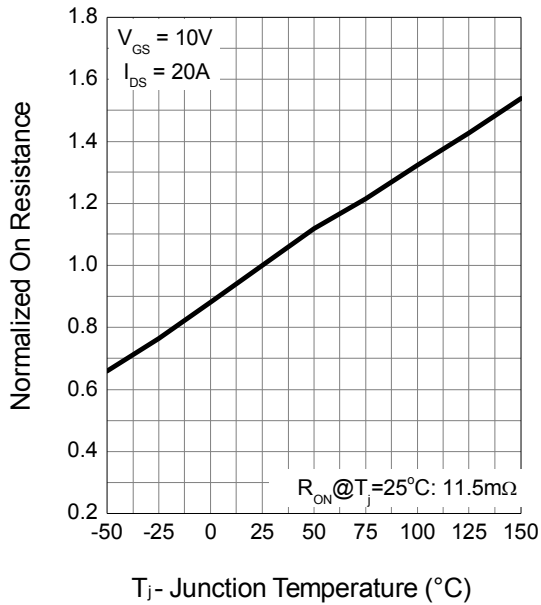

Source-Drain Diode Forward

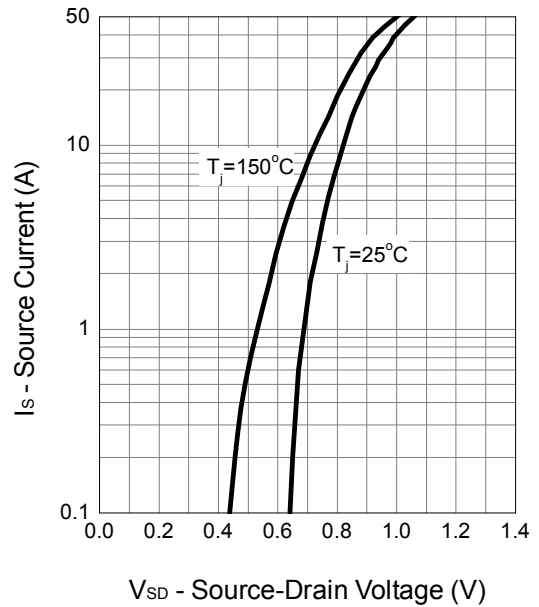

Capacitance

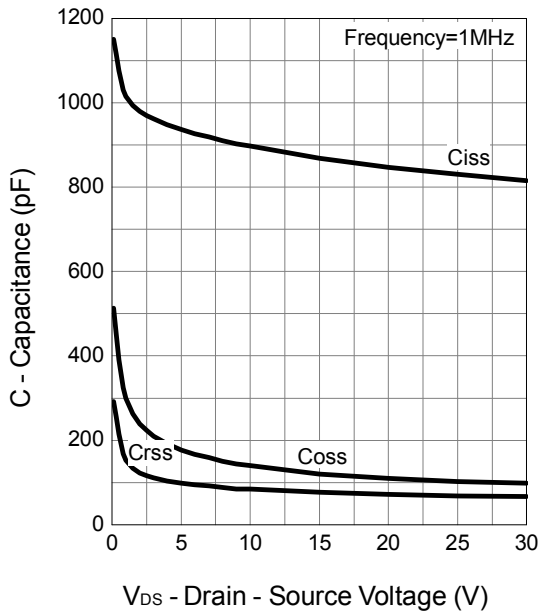

Gate Charge

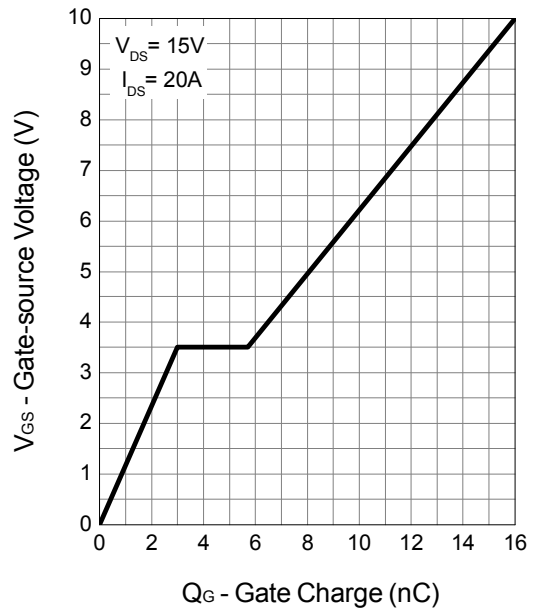

Avalanche Test Circuit and Waveforms

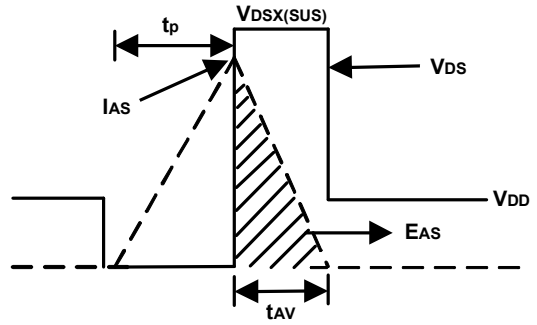
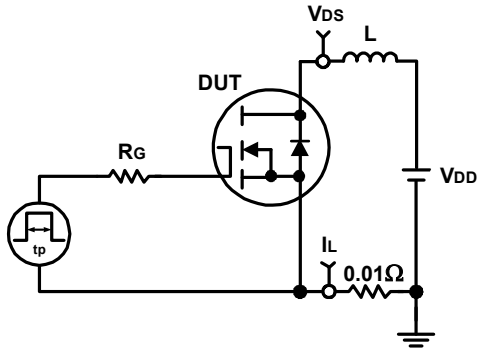

Switching Time Test Circuit and Waveforms

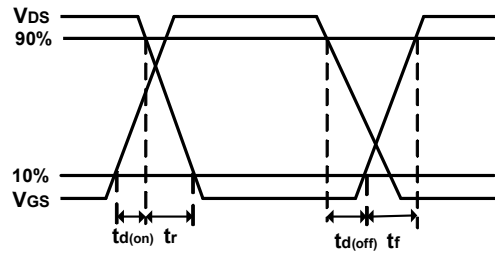
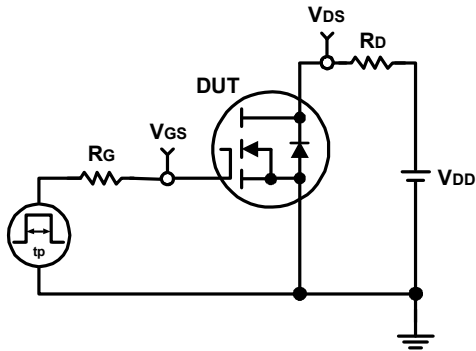

Package Information

TO-252-2

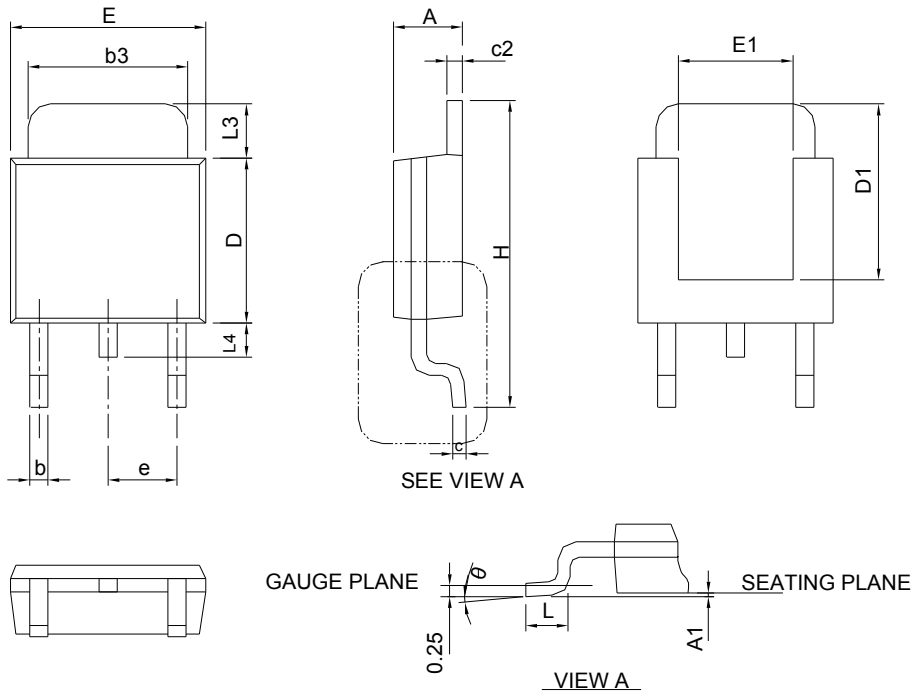

SYMBOL	TO-252-2			
	MILLIMETERS		INCHES	
	MIN.	MAX.	MIN.	MAX.
A	2.18	2.39	0.086	0.094
A1	-	0.13	-	0.005
b	0.50	0.89	0.020	0.035
b3	4.95	5.46	0.195	0.215
c	0.46	0.61	0.018	0.024
c2	0.46	0.89	0.018	0.035
D	5.33	6.22	0.210	0.245
D1	4.57	6.00	0.180	0.236
E	6.35	6.73	0.250	0.265
E1	3.81	6.00	0.150	0.236
e	2.29 BSC		0.090 BSC	
H	9.40	10.41	0.370	0.410
L	0.90	1.78	0.035	0.070
L3	0.89	2.03	0.035	0.080
L4	-	1.02	-	0.040
θ	0°	8°	0°	8°

Note : Follow JEDEC TO-252 .

RECOMMENDED LAND PATTERN

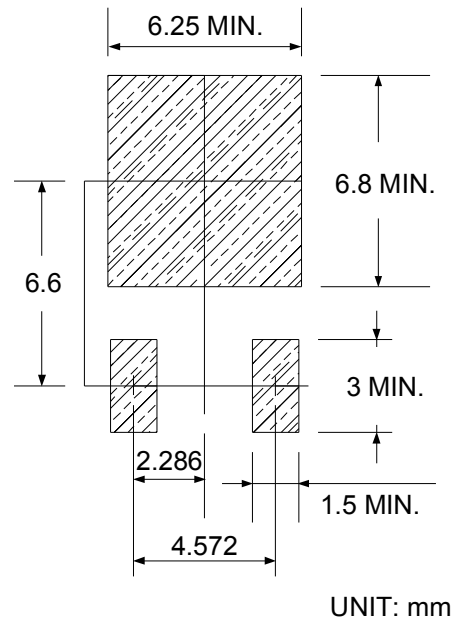

UNIT: mm