

Features

- 30V/8A,
 $R_{DS(ON)} = 18.5m\Omega(\text{typ.}) @ V_{GS} = 10V$
 $R_{DS(ON)} = 25m\Omega(\text{typ.}) @ V_{GS} = 4.5V$
- Reliable and Rugged
- Lead Free and Green Devices Available
 (RoHS Compliant)
- 100% UIS Tested

Pin Description

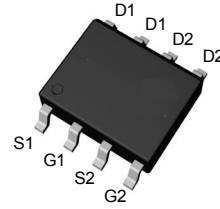

Top View of SOP8

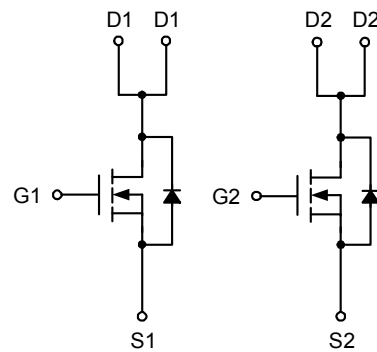

N-Channel MOSFET

Applications

- Power Management in Notebook Computer, Portable Equipment and Battery Powered Systems.

Absolute Maximum Ratings ($T_A = 25^\circ\text{C}$ Unless Otherwise Noted)

Symbol	Parameter	Rating	Unit	
V_{DSS}	Drain-Source Voltage	30	V	
V_{GSS}	Gate-Source Voltage	± 20		
I_D^a	Continuous Drain Current ($V_{GS}=10V$)	$T_A=25^\circ\text{C}$	8	A
		$T_A=70^\circ\text{C}$	6.5	
I_{DM}^a	300 μs Pulsed Drain Current ($V_{GS}=10V$)	40		
I_S^a	Diode Continuous Forward Current	1		
I_{AS}^b	Avalanche Current (Single Pulse)	9		
E_{AS}^b	Avalanche Energy, Single Pulse ($L=0.5\text{mH}$)	20	mJ	
T_J	Maximum Junction Temperature	150	$^\circ\text{C}$	
T_{STG}	Storage Temperature Range	-55 to 150		
P_D^a	Maximum Power Dissipation	$T_A=25^\circ\text{C}$	1.7	W
		$T_A=70^\circ\text{C}$	1.08	
$R_{\theta JA}^a$	Thermal Resistance-Junction to Ambient	$t \leq 10\text{s}$	48	$^\circ\text{C/W}$
		Steady State	74	
$R_{\theta JL}$	Thermal Resistance-Junction to Lead	Steady State	32	

Note a : Surface Mounted on 1in^2 pad area, $t \leq 10\text{sec}$. Maximum Power dissipation is calculated from $R_{\theta JA}$ (worst) = 62.5°C/W under $t \leq 10\text{s}$.

Note b : UIS tested and pulse width limited by maximum junction temperature 150°C (initial temperature $T_J=25^\circ\text{C}$).

Electrical Characteristics ($T_A = 25^\circ\text{C}$ Unless Otherwise Noted)

Symbol	Parameter	Test Conditions	XP4812			Unit
			Min.	Typ.	Max.	
Static Characteristics						
BV_{DSS}	Drain-Source Breakdown Voltage	$V_{GS}=0V, I_{DS}=250\mu A$	30	-	-	V
I_{DSS}	Zero Gate Voltage Drain Current	$V_{DS}=24V, V_{GS}=0V$	-	-	1	μA
		$T_J=85^\circ C$	-	-	30	
$V_{GS(th)}$	Gate Threshold Voltage	$V_{DS}=V_{GS}, I_{DS}=250\mu A$	1.3	1.9	2.5	V
I_{GSS}	Gate Leakage Current	$V_{GS}=\pm 20V, V_{DS}=0V$	-	-	± 100	nA
$R_{DS(ON)}^a$	Drain-Source On-state Resistance	$V_{GS}=10V, I_{DS}=8A$	-	18.5	23	m Ω
		$V_{GS}=4.5V, I_{DS}=7A$	-	25	27	
Gfs	Forward Transconductance	$V_{DS}=5V, I_{DS}=8A$	-	32	-	S
Diode Characteristics						
V_{SD}^a	Diode Forward Voltage	$I_{SD}=1A, V_{GS}=0V$	-	0.7	1.1	V
t_{rr}^b	Reverse Recovery Time	$I_{SD}=8A, di_{SD}/dt=100A/\mu s$	-	15.5	-	ns
Q_{rr}^b	Reverse Recovery Charge		-	6.5	-	nC
Dynamic Characteristics^b						
R_G	Gate Resistance	$V_{GS}=0V, V_{DS}=0V, F=1MHz$	1.3	1.7	2.3	Ω
C_{iss}	Input Capacitance	$V_{GS}=0V,$ $V_{DS}=15V,$ Frequency=1.0MHz	-	580	-	pF
C_{oss}	Output Capacitance		-	95	-	
C_{riss}	Reverse Transfer Capacitance		-	57	-	
$t_{d(ON)}$	Turn-on Delay Time	$V_{DD}=15V, R_L=15\Omega,$ $I_{DS}=1A, V_{GEN}=10V,$ $R_G=6\Omega$	-	5.9	10	ns
t_r	Turn-on Rise Time		-	10	17	
$t_{d(OFF)}$	Turn-off Delay Time		-	17	35	
t_f	Turn-off Fall Time		-	4	9	
Gate Charge Characteristics^b						
Q_g	Total Gate Charge	$V_{DS}=15V, V_{GS}=10V,$ $I_{DS}=8A$	-	10.2	14	nC
	Total Gate Charge		-	5.3	-	
Q_{gth}	Threshold Gate Charge	$V_{DS}=15V, V_{GS}=4.5V,$ $I_{DS}=8A$	-	0.78	-	
Q_{gs}	Gate-Source Charge		-	1.7	-	
Q_{gd}	Gate-Drain Charge		-	2.2	-	

Note a : Pulse test ; pulse width $\leq 300 \mu s$, duty cycle $\leq 2\%$.

Note b : Guaranteed by design, not subject to production testing.

Typical Operating Characteristics

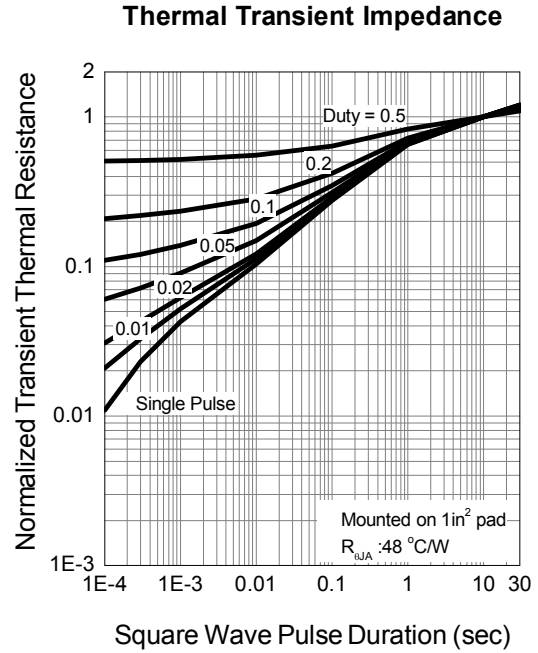
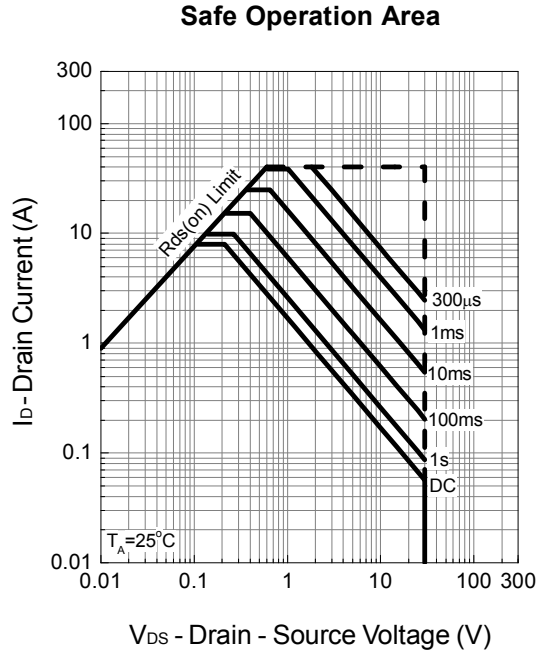
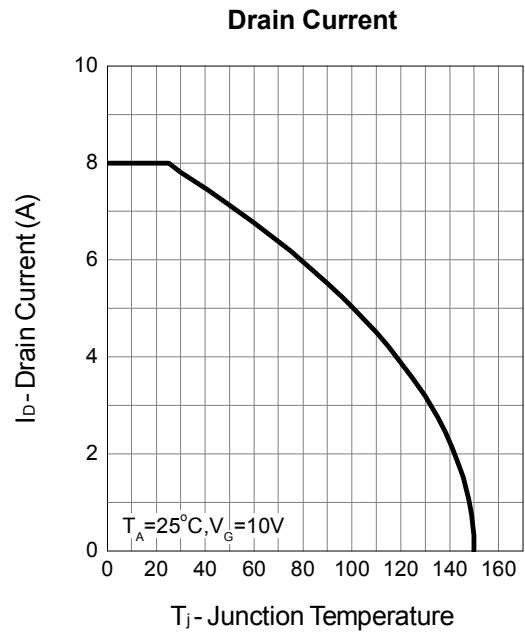
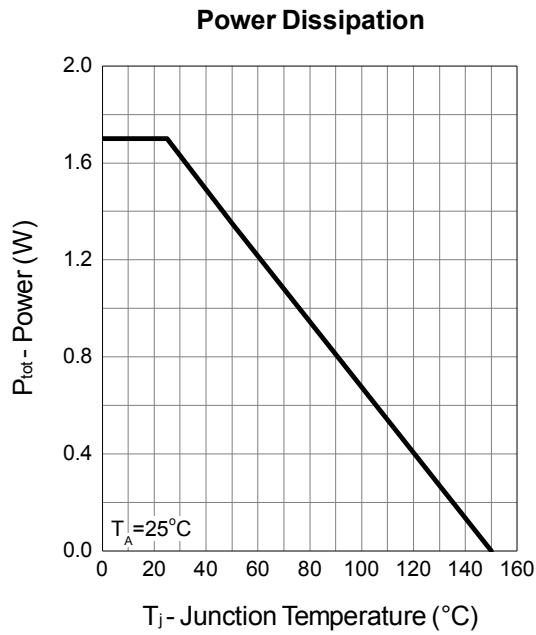

Typical Operating Characteristics (Cont.)

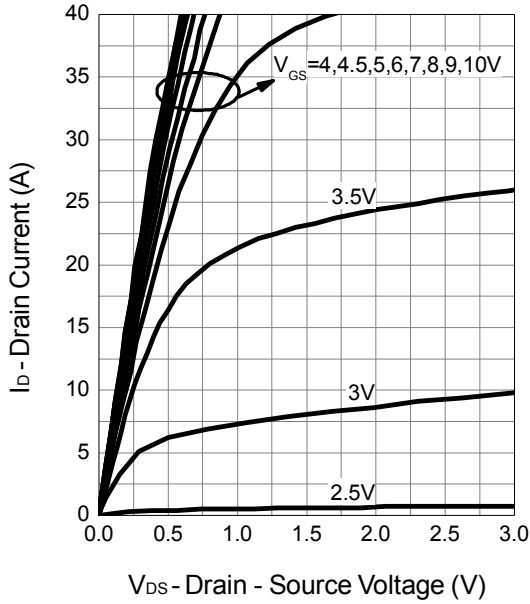
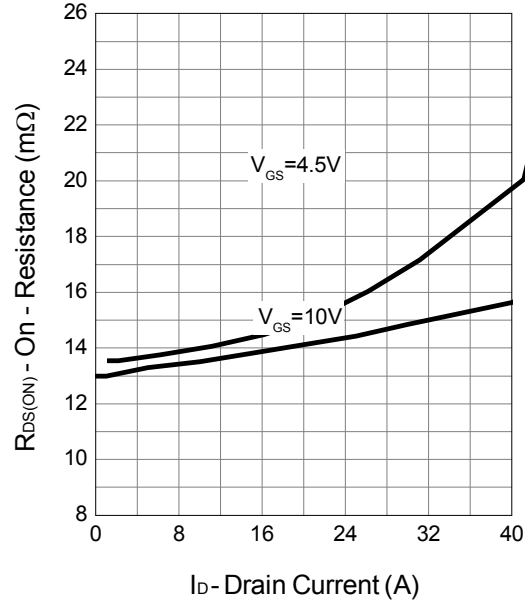
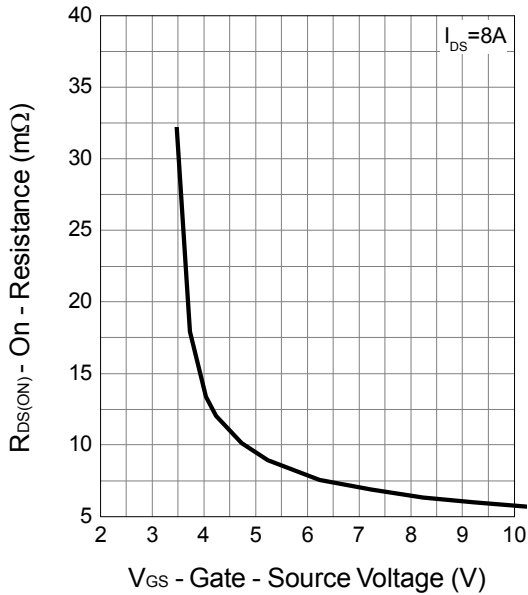
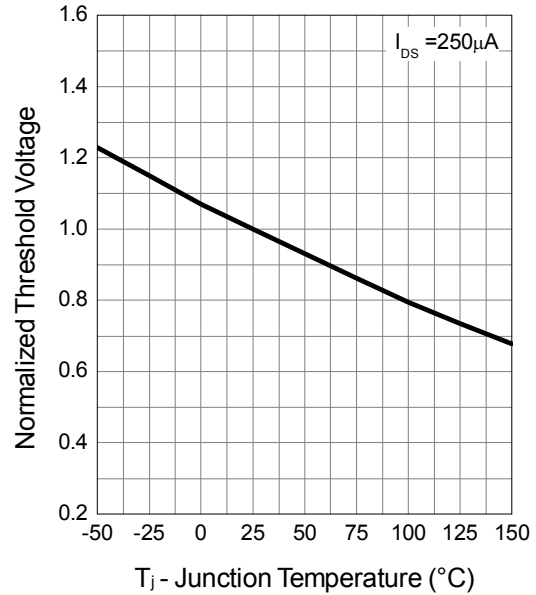
Output Characteristics

Drain-Source On Resistance

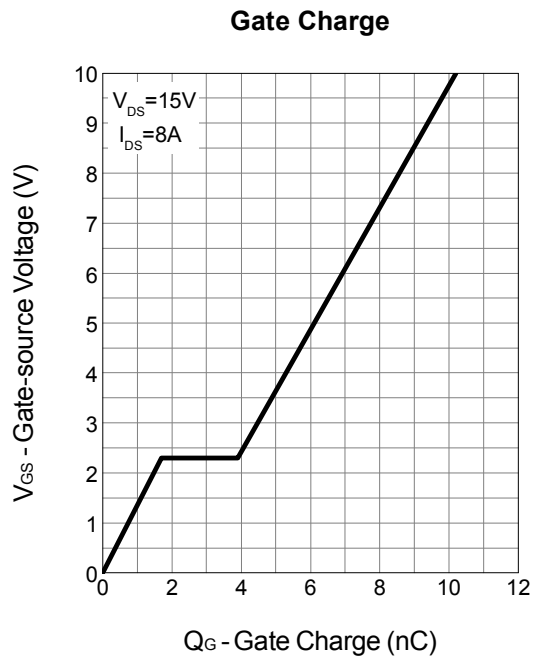
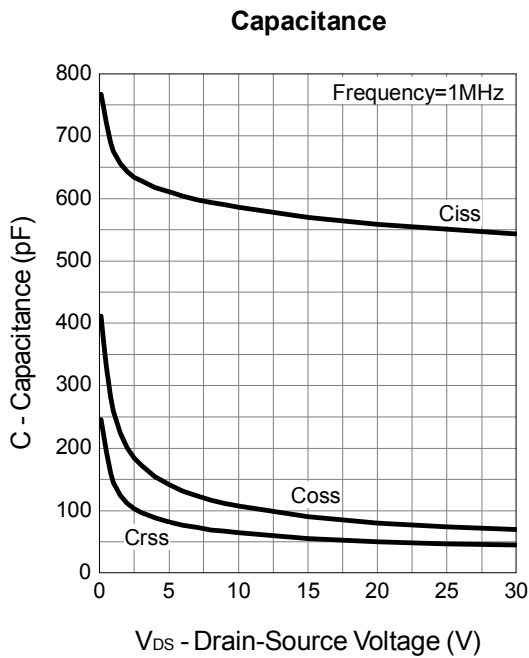
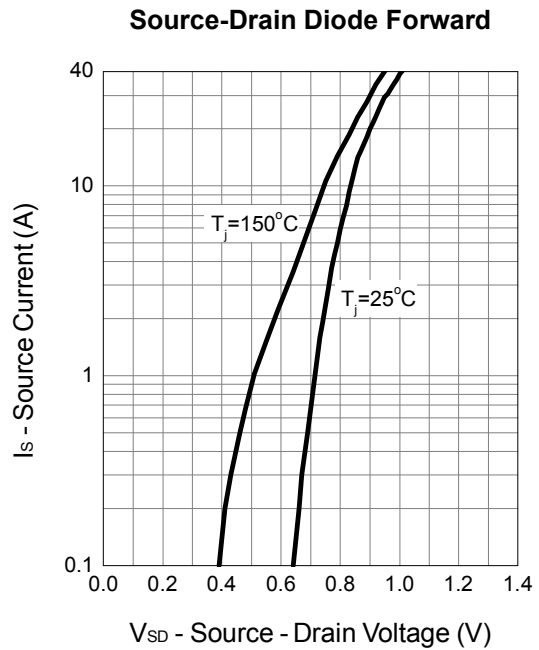
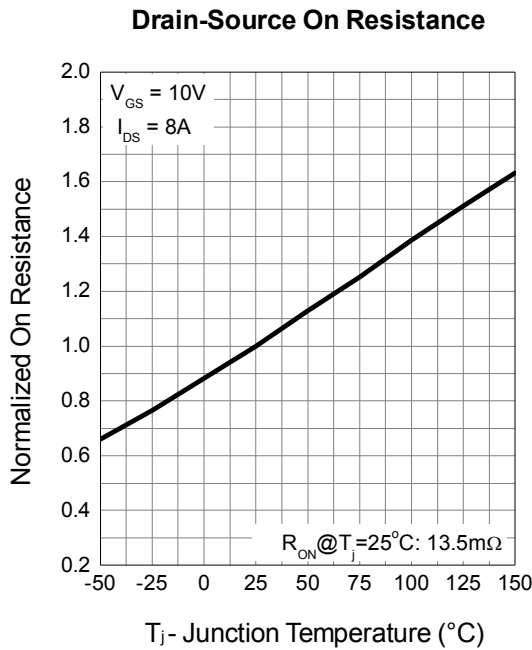
Gate-Source On Resistance

Gate Threshold Voltage

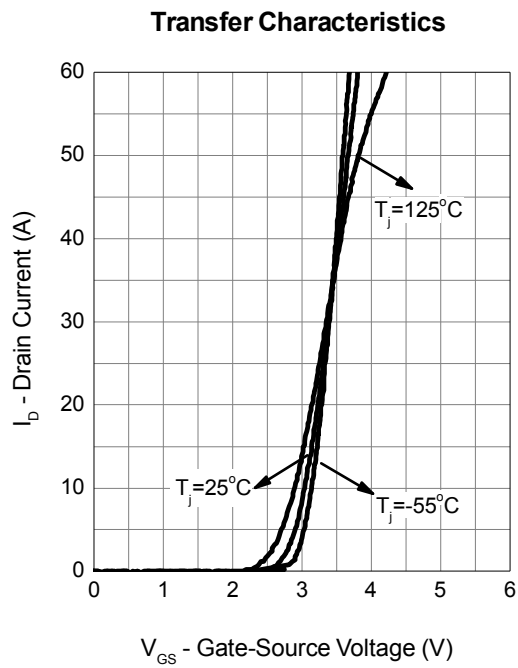
Typical Operating Characteristics (Cont.)



Typical Operating Characteristics (Cont.)



Avalanche Test Circuit and Waveforms

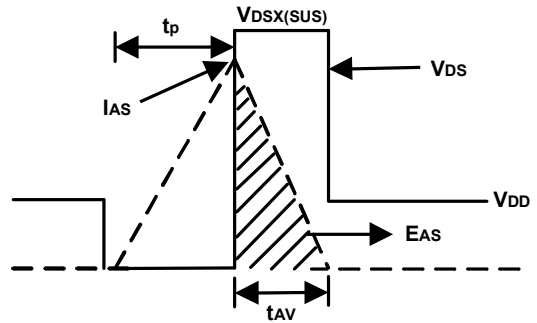
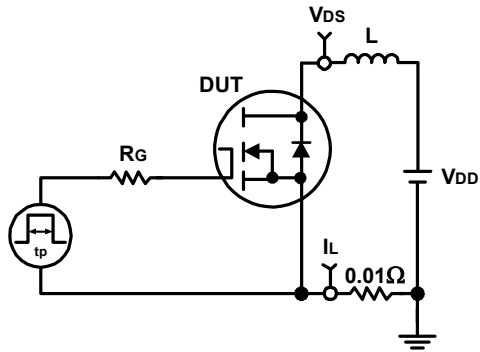

Switching Time Test Circuit and Waveforms

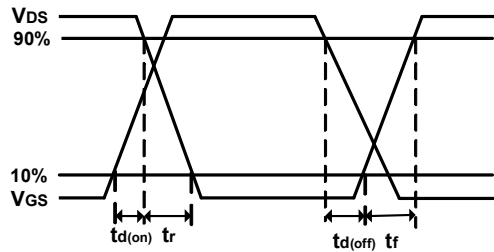
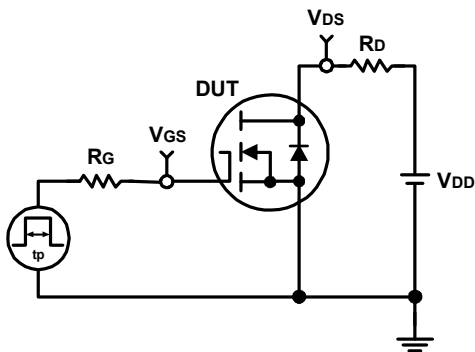

SOP8 PACKAGE OUTLINE

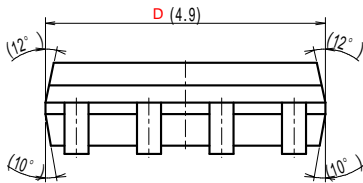
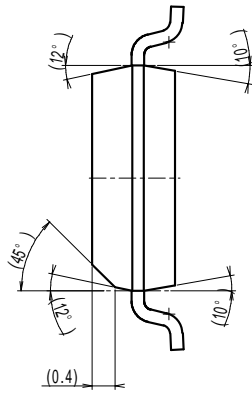
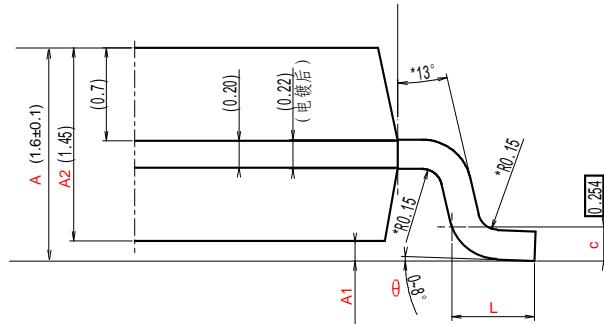
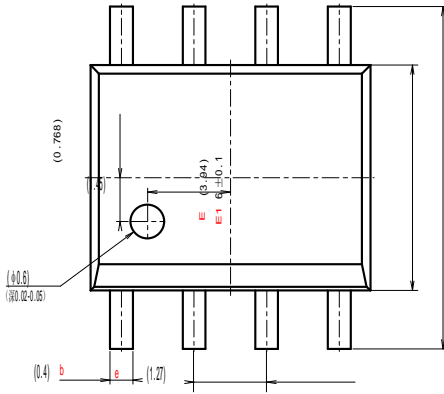

字符	Dimension millimeters		
	Min	Standard	Max
A	1.500	1.600	1.700
A1	0.040	0.080	0.150
A2	1.350	1.450	1.550
b	0.300	0.400	0.500
c	0.220	0.254	0.280
D	4.800	4.900	5.000
E	3.840	3.940	4.040
E1	5.900	6.000	6.100
e		1.27 (BSC)	
L	0.400	0.550	0.700
θ	0°		8°