

## Features

- 30V/4.7A,  
 $R_{DS(ON)} = 38m\Omega(\text{typ.}) @ V_{GS} = 4.5V$   
 $R_{DS(ON)} = 43m\Omega(\text{typ.}) @ V_{GS} = 2.5V$
- Reliable and Rugged
- Lead Free and Green Devices Available (RoHS Compliant)

## Pin Description

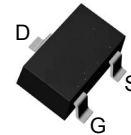

Top View of SOT23-3L

## Applications

- Power Management in Desktop Computer or DC/DC Converters.
- Power Load Switch.
- Notebook Battery Management.

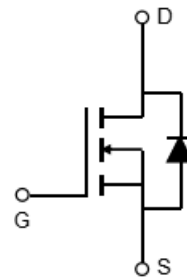

N-Channel MOSFET

## Absolute Maximum Ratings ( $T_A = 25^\circ\text{C}$ unless otherwise noted)

Symbol	Parameter	Rating	Unit	
$V_{DSS}$	Drain-Source Voltage	30	V	
$V_{GSS}$	Gate-Source Voltage	$\pm 20$		
$I_D$	Continuous Drain Current	$T_A = 25^\circ\text{C}$	4.7	A
		$T_A = 70^\circ\text{C}$	3.7	
$I_{DM}$	300 $\mu\text{s}$ Pulsed Drain Current	$V_{GS} = 10V$	18	
$I_S$	Diode Continuous Forward Current		1	A
$T_J$	Maximum Junction Temperature		150	$^\circ\text{C}$
$T_{STG}$	Storage Temperature Range		-55 to 150	
$P_D$	Maximum Power Dissipation	$T_A = 25^\circ\text{C}$	1.4	W
		$T_A = 70^\circ\text{C}$	0.9	
$R_{\theta JA}^*$	Thermal Resistance-Junction to Ambient	$t \leq 10\text{sec}$	90	$^\circ\text{C/W}$
		Steady state	140	

Note: \*Surface Mounted on 1in<sup>2</sup> pad area,  $t \leq 10\text{sec}$ .

**Electrical Characteristics** ( $T_A = 25^\circ\text{C}$  unless otherwise noted)

Symbol	Parameter	Test Conditions	Min.	Typ.	Max.	Unit	
<b>Static Characteristics</b>							
$BV_{DSS}$	Drain-Source Breakdown Voltage	$V_{GS}=0V, I_{DS}=250\mu A$	30	-	-	V	
$I_{DSS}$	Zero Gate Voltage Drain Current	$V_{DS}=24V, V_{GS}=0V$	-	-	1	$\mu A$	
		$T_J=85^\circ C$	-	-	30		
$V_{GS(th)}$	Gate Threshold Voltage	$V_{DS}=V_{GS}, I_{DS}=250\mu A$	0.5	0.8	1.1	V	
$I_{GSS}$	Gate Leakage Current	$V_{GS}=\pm 20V, V_{DS}=0V$	-	-	$\pm 100$	nA	
$R_{DS(ON)}^a$	Drain-Source On-State Resistance	$V_{GS}=4.5V, I_{DS}=4A$	-	38	46	m $\Omega$	
		$V_{GS}=2.5V, I_{DS}=3A$	-	43	52		
<b>Diode Characteristics</b>							
$V_{SD}^a$	Diode Forward Voltage	$I_{SD}=1A, V_{GS}=0V$	-	0.75	1.1	V	
$t_{rr}$	Reverse Recovery Time	$I_{SD}=4A, dI_{SD}/dt=100A/\mu s$	-	10	-	ns	
$Q_{rr}$	Reverse Recovery Charge		-	4	-	nC	
<b>Dynamic Characteristics<sup>b</sup></b>							
$R_g$	Gate Resistance	$V_{GS}=0V, V_{DS}=0V, F=1MHz$	-	2.1	-	$\Omega$	
$C_{iss}$	Input Capacitance	$V_{GS}=0V,$ $V_{DS}=15V,$ Frequency=1.0MHz	-	240	-	pF	
$C_{oss}$	Output Capacitance		-	40	-		
$C_{rss}$	Reverse Transfer Capacitance		-	30	-		
$t_{d(ON)}$	Turn-on Delay Time	$V_{DD}=15V, R_L=15\Omega,$ $I_{DS}=1A, V_{GEN}=10V,$ $R_G=6\Omega$	-	4.5	9	ns	
$T_r$	Turn-on Rise Time		-	11	21		
$t_{d(OFF)}$	Turn-off Delay Time		-	11	21		
$T_f$	Turn-off Fall Time		-	2.6	5		
<b>Gate Charge Characteristics<sup>b</sup></b>							
$Q_g$	Total Gate Charge	$V_{DS}=15V,$ $I_{DS}=4A$	$V_{GS}=4.5V,$	-	3	-	nC
			$V_{GS}=10V$	-	6.2	-	
$Q_{gs}$	Gate-Source Charge	$V_{DS}=15V, V_{GS}=10V,$ $I_{DS}=4A$	-	0.8	-		
$Q_{gd}$	Gate-Drain Charge		-	1.6	-		
$Q_{gth}$	Threshold Gate Charge		-	3.1	-		

 Note a: Pulse test; pulse width $\leq 300\mu s$ , duty cycle $\leq 2\%$ .

Note b: Guaranteed by design, not subject to production testing.

### Typical Operating Characteristics

Power Dissipation

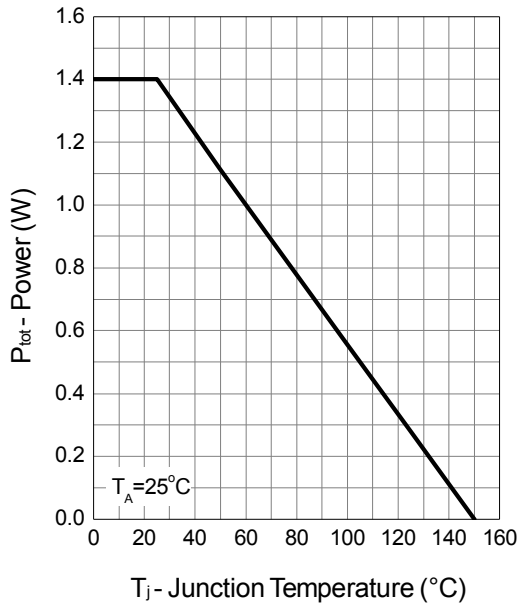

Drain Current

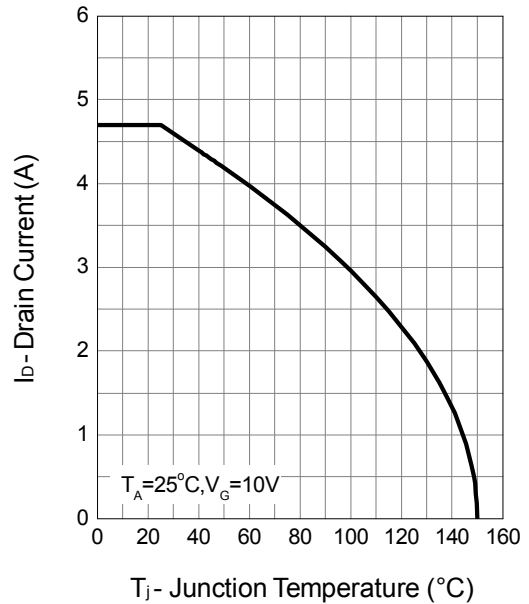

Safe Operation Area

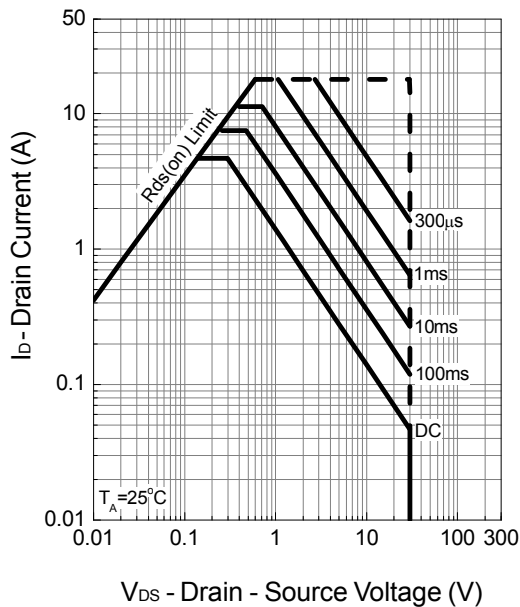

Thermal Transient Impedance

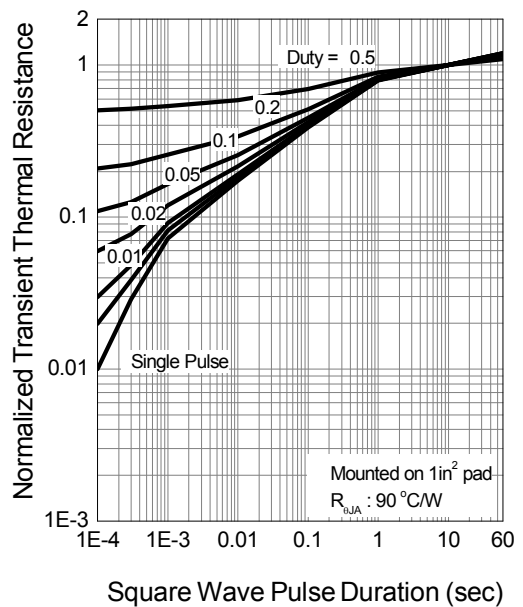

### Typical Operating Characteristics (Cont.)

Output Characteristics

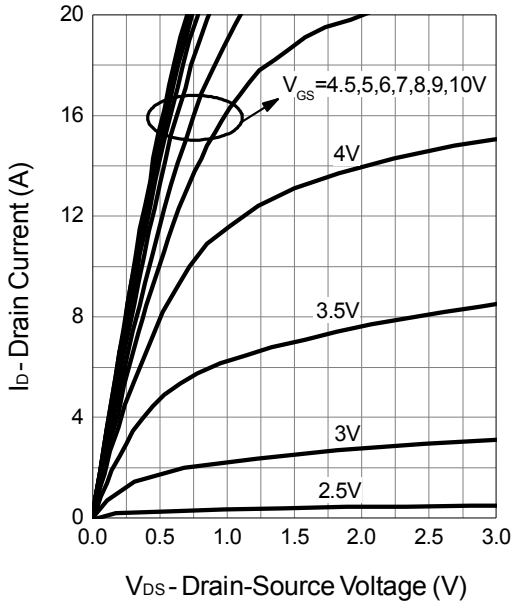

Drain-Source On Resistance

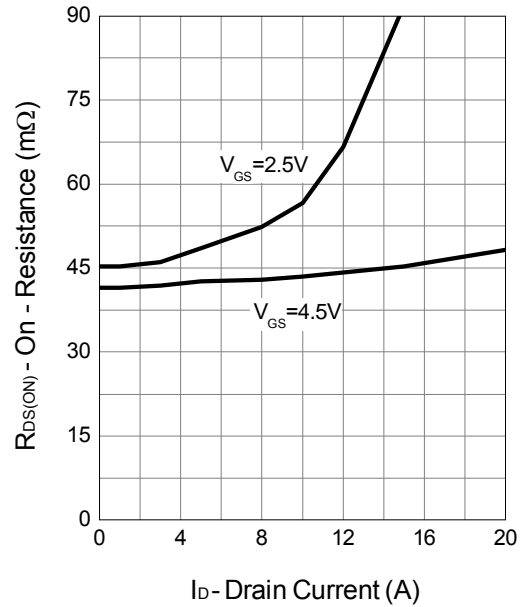

Gate-Source On Resistance

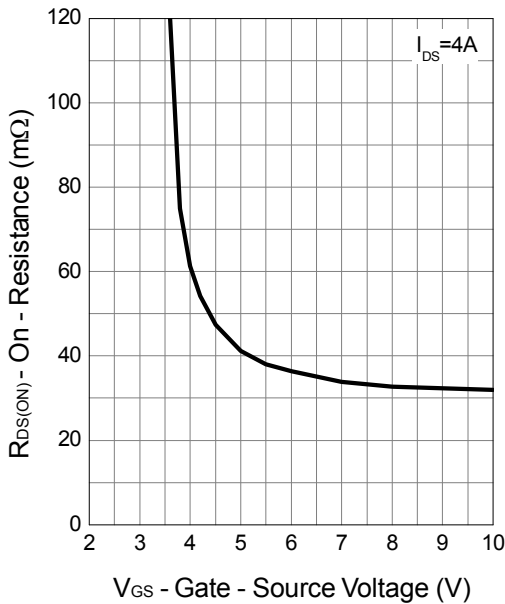

Gate Threshold Voltage

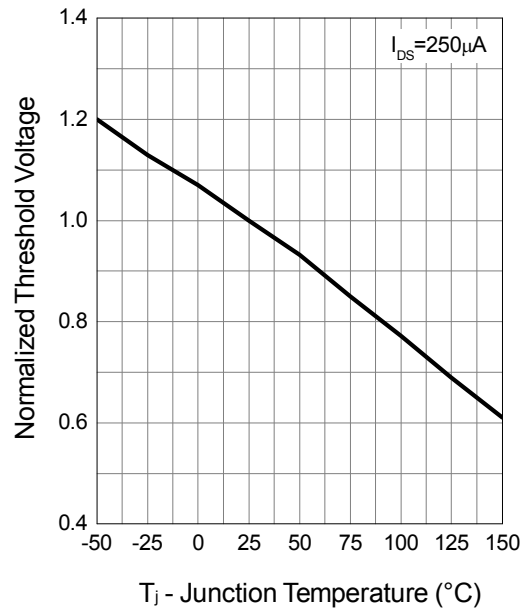

### Typical Operating Characteristics (Cont.)

**Drain-Source On Resistance**

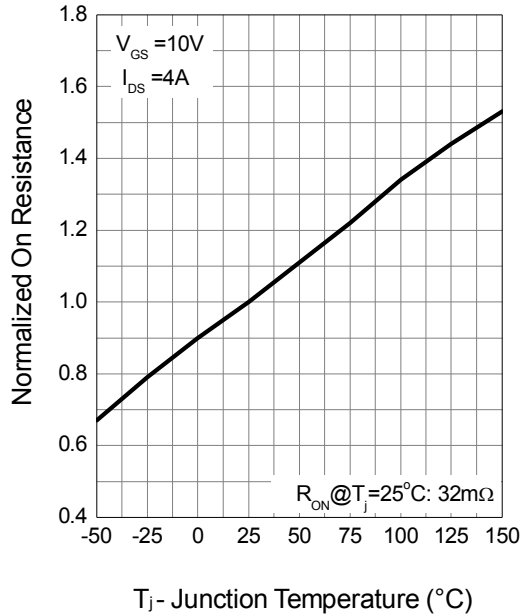

**Source-Drain Diode Forward**

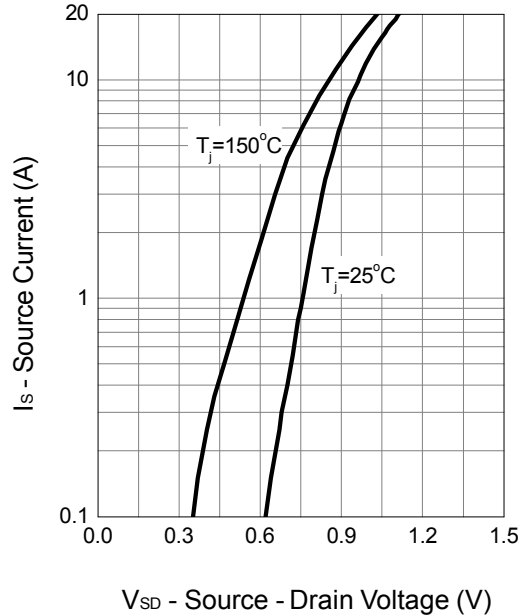

**Capacitance**

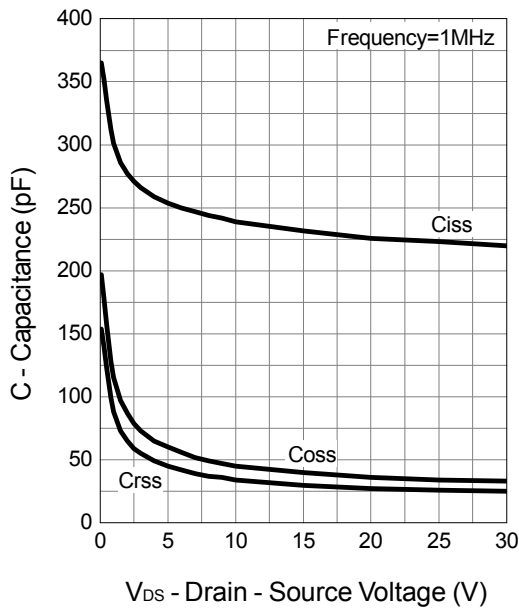

**Gate Charge**

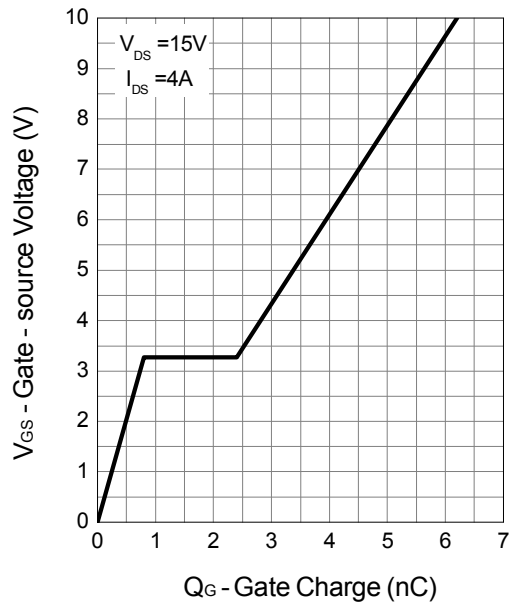

### Avalanche Test Circuit and Waveforms

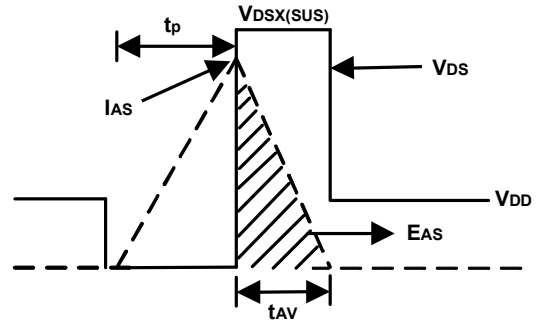
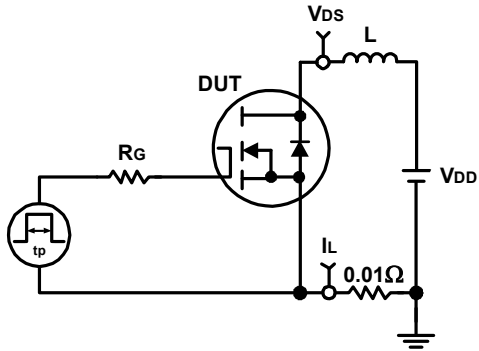

### Switching Time Test Circuit and Waveforms

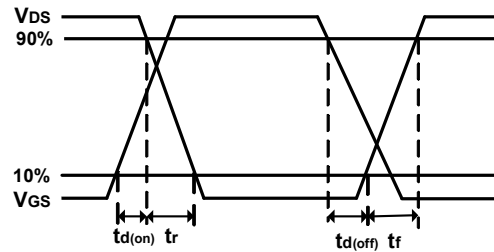
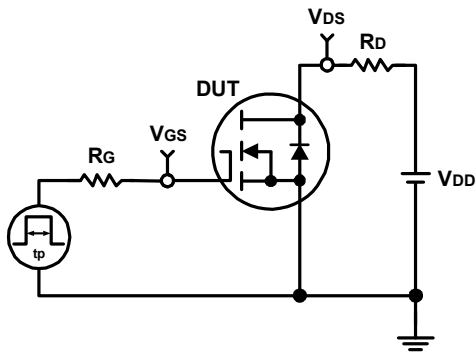

## Package Information

### SOT23-3L

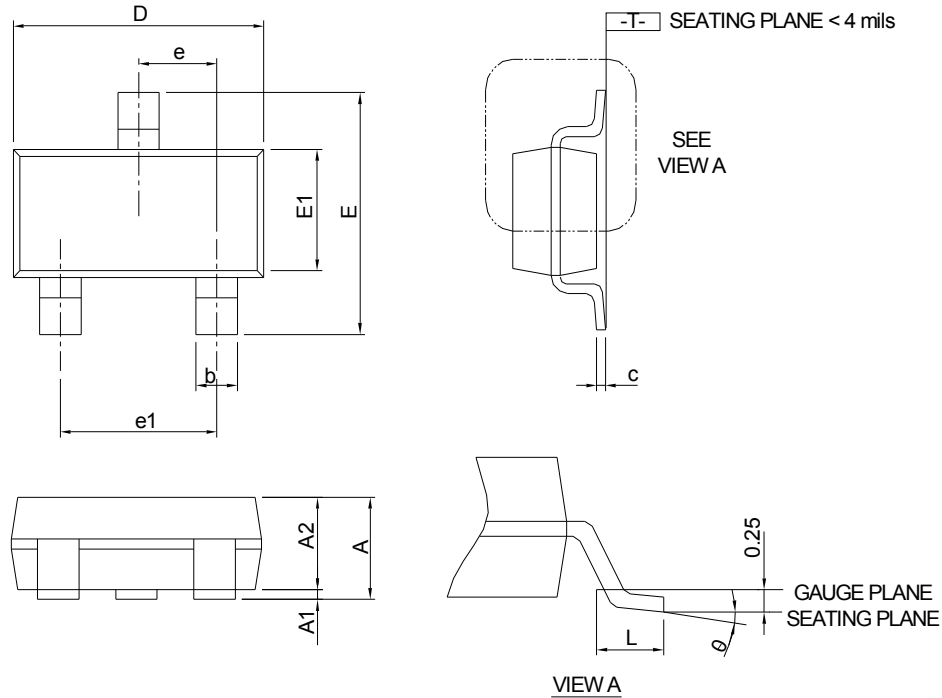

SYMBOL	SOT 23-3L			
	MILLIMETERS		INCHES	
	MIN.	MAX.	MIN.	MAX.
A		1.20		0.047
A1	0.00	0.08	0.000	0.003
A2	0.90	1.12	0.035	0.044
b	0.30	0.50	0.012	0.020
c	0.08	0.22	0.003	0.009
D	2.70	3.10	0.106	0.122
E	2.60	3.00	0.102	0.118
E1	1.40	1.80	0.055	0.071
e	0.95 BSC		0.037 BSC	
e1	1.90 BSC		0.075 BSC	
L	0.30	0.60	0.012	0.024
θ	0°	8°	0°	8°

### RECOMMENDED LAND PATTERN

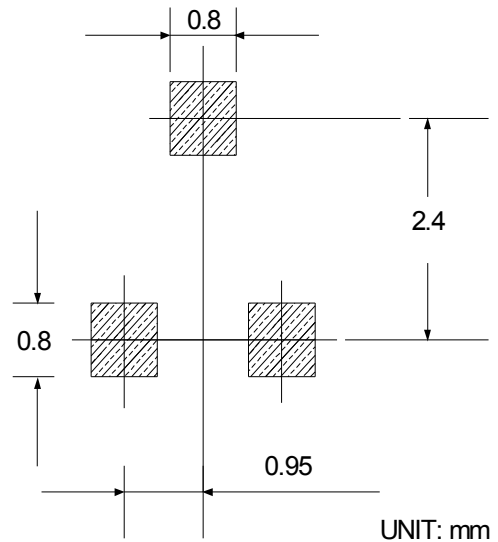

Note : Dimension D and E1 do not include mold flash, protrusions or gate burrs. Mold flash, protrusion or gate burrs shall not exceed 10 mil per side.