

General Description

The RST9801 is an overvoltage protection devices feature a low $100\text{m}\Omega$ (Typ) RON internal MOSFET. When the input voltage exceeds the overvoltage threshold, the internal MOSFET is turned off to prevent damage to the protected down stream components. The internal Over Voltage Thresholds (OVP) are preset to 6.0V typical. The RST9801 also feature an over-current protection and up to 3A. RST9801 adopts the commonly used SOT-23-3 & SOT-23-6 & SOT-89-3 and DFN2x2-8L packages, which is convenient for the application of various products.

Features

- Input maximum withstand voltage to 36V
- 6.0V Input Over-Voltage Protection
- Fast Over-Voltage Protection Response to 0.2uS
- $100\text{m}\Omega$ ultra-low internal $R_{DS(ON)}$
- Built-in 2mS soft start
- Over-Current Protection
- Short Circuit Protection
- Over-Temperature Protection
- SOT-23-3 & SOT-23-6 & SOT-89-3 & DFN2x2-8L Package Available

Applications

- Laptop, Palmtops and PDAs
- Smart Phones
- MP3 Players
- Low-Power Handheld Devices
- TWS & E-Cig

Pin Configurations

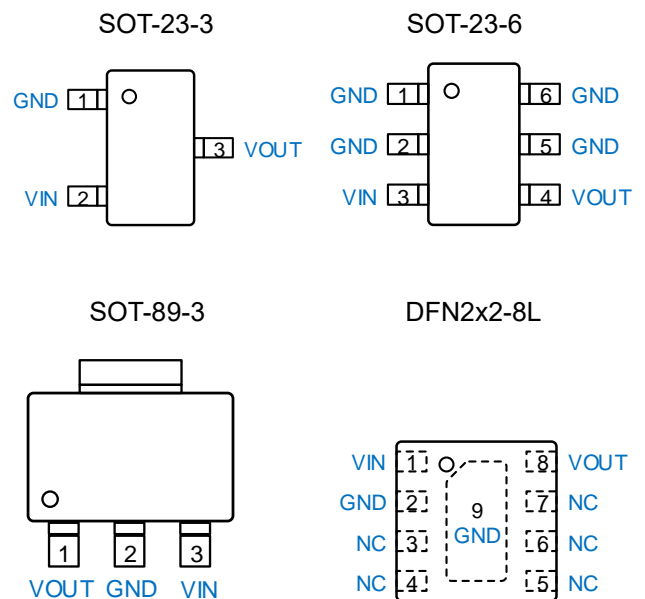

Ordering Information

RST9801XY

Designator	Description	Symbol	Description
X	Over-Current type	A	2A
		B	3A
YY	Package type	S3R	SOT-23-3
		S6	SOT-23-6
		A3	SOT-89-3
		D22	DFN2x2-8L

Example: OCP=2A, SOT-23-6. Part no = RST9801AS6.

Description of Functional Pins

Pin No				Pin Name	Pin Function
SOT-23-3	SOT-23-6	SOT-89-3	DFN2x2-8L		
1	1, 2, 5, 6	2	2	GND	Ground .
2	3	3	1	VIN	Input of Supply Voltage .
3	4	1	8	VOUT	Output Pin .
3	4	1	3, 4, 5, 6, 7	NC	No Internal Connection.

Typical Application Circuits

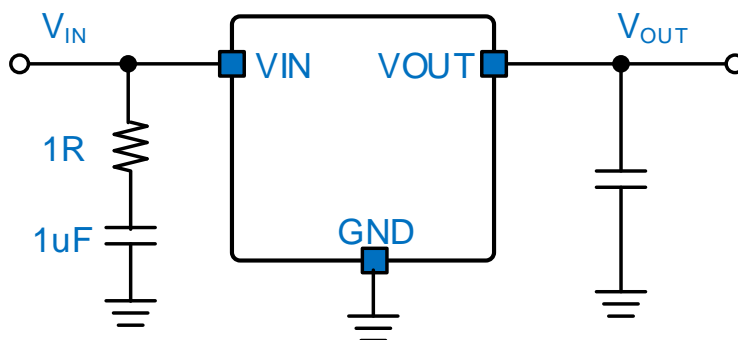

Function Block Diagram

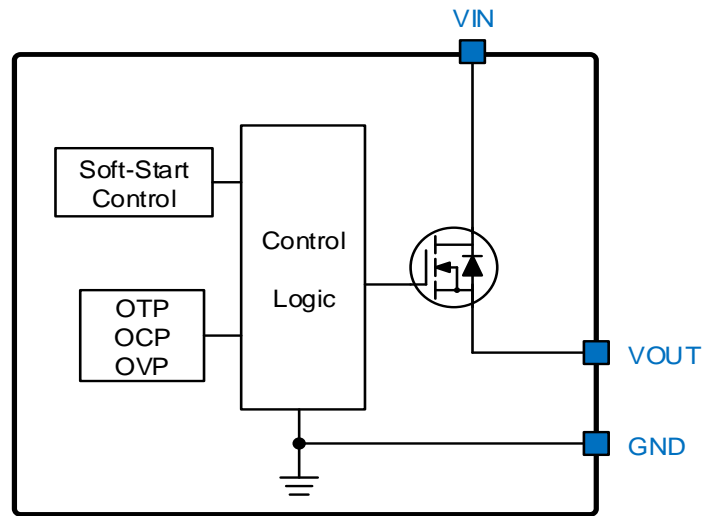

Absolute Maximum Ratings (Note 1)

VIN to GND	-----	-0.3V to 36V
VOUT to GND	-----	-0.3V to 6V
Package Thermal Resistance (Note 2)		
SOT-23-3 & SOT-23-6, θ_{JA}	-----	200 °C /W
SOT-89-3, θ_{JA}	-----	120 °C /W
DFN2x2-8L, θ_{JA}	-----	95 °C /W
Lead Temperature (Soldering, 10 sec.)	-----	260 °C
Junction Temperature	-----	150 °C
Storage Temperature Range	-----	-60 °C to 150 °C
ESD Susceptibility		
HBM	-----	2KV
MM	-----	200V

Recommended Operating Conditions

Input Voltage VIN	-----	2.2V to 6V
Junction Temperature Range	-----	-40 °C to 125 °C
Ambient Temperature Range	-----	-40 °C to 85 °C

Electrical Characteristics

 ($V_{IN} = 5V$, $T_A = 25^\circ C$ unless otherwise specified)

Parameter	Symbol	Test Conditions	Min	Typ	Max	Unit
Supply Voltage	V_{IN}		2.2	--	6	V
UVLO Threshold Voltage	V_{IN_UVLO}	V_{IN} Rising	--	2.9	--	V
UVLO Hysteresis Voltage	V_{UVLO_HYS}		--	1.0	--	V
Input Supply Current	I_Q			50		μA
Deglitch Time of POR	T_{POR}			20		mS
Soft-Start Time	T_{SS}	V_{OUT} 10% to 90%		1.0		mS
VIN-to-VOUT ON Resistance	R_{ON}			100		$m\Omega$
VOUT Discharge Resistance	R_{DIS}			500		Ω
Input Over-Voltage Protection (OVP)						
Over-Voltage Protection	V_{OVP}		5.82	6.0	6.18	V
Over-Voltage Protection Hysteresis	V_{OVP_HYS}			300		mV
OVP Propagation Delay to Turn Off	T_{OVP_PD}		--	0.2		μS
OVP Recover Delay Time	T_{OVP_RD}		--	20	--	mS
Input Over-Current Protection (OCP)						
Over-Current Protection	Type A		2	2.5		A
	Type B		3	3.5		
OC Blanking Time	T_{OCP_BT}		--	8		mS
OCP Recover Delay Time	T_{OCP_RD}		--	800	--	mS
Over-Temperature Protection (OTP)						
Thermal Shutdown Temperature	T_{SD}	$I_{LOAD} = 10mA$	--	150	--	$^\circ C$
Thermal Shutdown Hysteresis	ΔT_{SD}				30	

Note 1. Stresses beyond those listed “Absolute Maximum Ratings” may cause permanent damage to the device. These are stress ratings only, and functional operation of the device at these or any other conditions beyond those indicated in the operational sections of the specifications is not implied. Exposure to absolute maximum rating conditions may affect device reliability.

Note 2. θ_{JA} is measured at $T_A = 25^\circ C$ on a DSTTECH EVB board.

Typical Characteristics

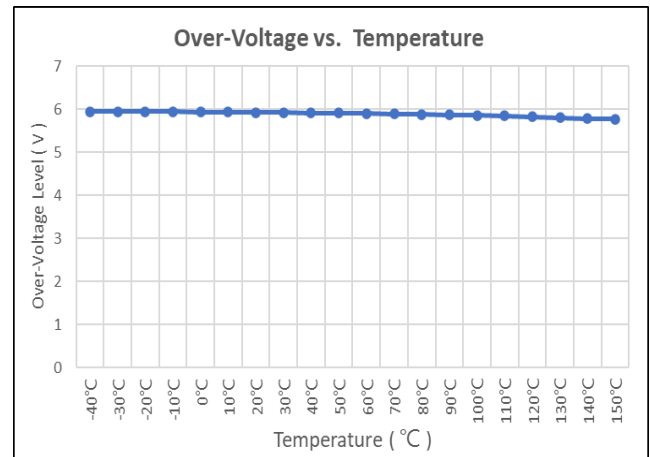
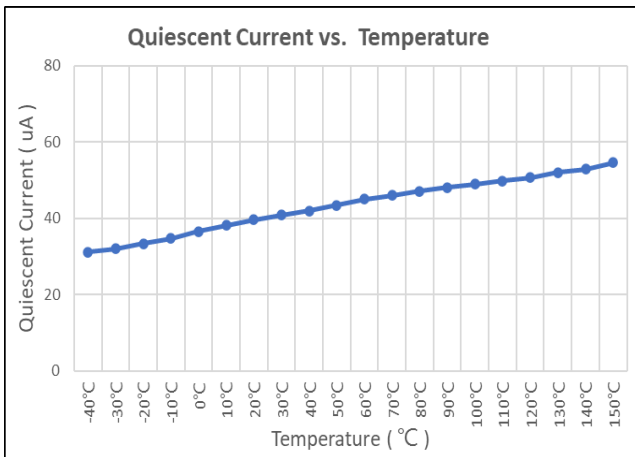
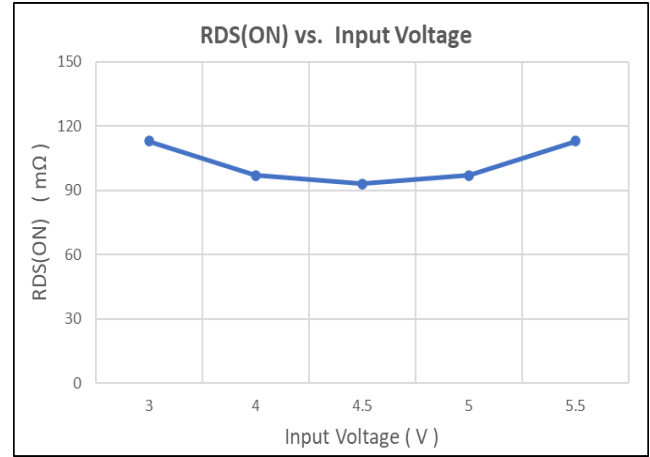
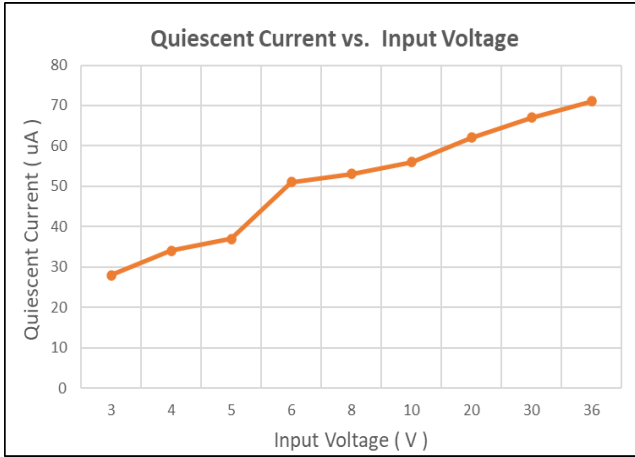

Application Guideline

Power-up

The RST9801 has a threshold of 2.9V power on reset (POR) with a built-in hysteresis of 500mV. Before the input voltage reaches the POR threshold, the RST9801 is off. When the input voltage is over the POR threshold, the VOUT of RST9801 will delay for 20ms which includes soft-start time of 1ms. The 20ms delay allows the transient at the input during a hot insertion of the power supply to settle down before the IC starts to operate. During the soft-start transition, the RST9801 slowly turns on the internal MOSFET to reduce the inrush current.

Input Over-Voltage Protection (OVP)

The RST9801 provides input over-voltage protection via internal set OVP level. when the input volatge exceeds the OVP level, the RST9801 will turn off internal MOSFET around 0.2us to prevent the high input voltage from damaging the end system. When the input voltage returns to normal operation volatge range with hysteresis (300mV), the RST9801 delay 20mS will turn on the MOSFET to re-enable output.

Over-Current Protection (OCP)

The RST9801 monitors the output current to prevent the output Over-Cuuent or Output short .

The RST9801 has a built-in 8ms delay time to prevent any transient noise triggering the OCP. If the OCP situation keeps for 8ms, the internal MOSFET will be turned off. And RST9801 also has short-circuit protection and no delay time.

Thermal Application

For continuous operation, do not exceed the absolute maximum junction temperature. The maximum power dissipation depends on the thermal resistance of the IC package, PCB layout, rate of surrounding airflow, and difference between junction and ambient temperature. The maximum power dissipation can be calculated as below:

$T_A=25^{\circ}\text{C}$, DSTECH PCB,

The max PD (Max) = $(125^{\circ}\text{C} - 25^{\circ}\text{C}) / (200^{\circ}\text{C}/\text{W}) = 0.5\text{W}$ for SOT-23-3 & SOT-23-6 packages.

The max PD (Max) = $(125^{\circ}\text{C} - 25^{\circ}\text{C}) / (120^{\circ}\text{C}/\text{W}) = 0.83\text{W}$ for SOT-89-3 packages.

The max PD (Max) = $(125^{\circ}\text{C} - 25^{\circ}\text{C}) / (95^{\circ}\text{C}/\text{W}) = 1.05\text{W}$ for DFN2x2-8L packages.

Power dissipation (PD) is equal to the product of the output current and the voltage drop across the output pass element, as shown in the equation below:

$$\text{PD} = (\text{VIN} - \text{VOUT}) \times \text{IOUT}$$

Layout Consideration

By placing input and output capacitors on the same side of the PCB as the Charger, and placing them as close as is practical to the package can achieve the best performance. The ground connections for input and output capacitors must be back to the RST9801 ground pin using as wide and as short of a copper trace as is practical.

Connections using long trace lengths, narrow trace widths, and/or connections through via must be avoided. These add parasitic inductances and resistance that results in worse performance especially during transient conditions.

Package Information:

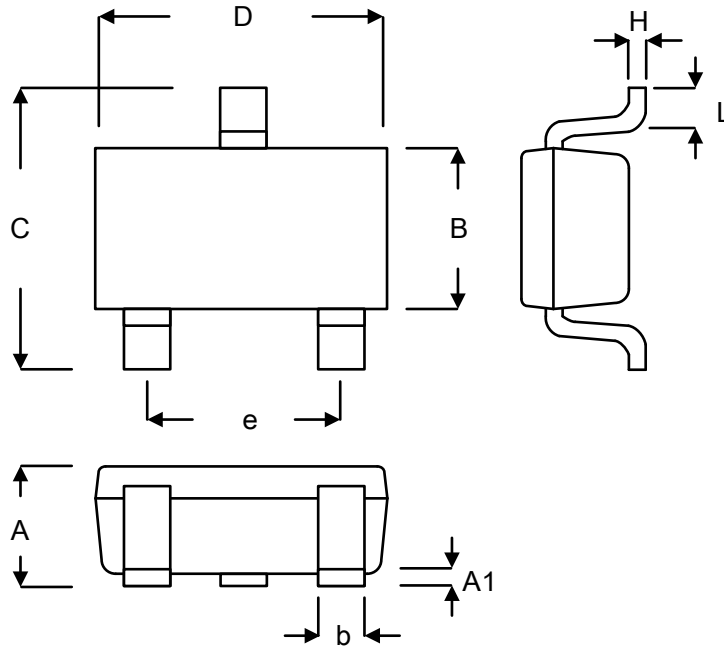

Symbol	Millimeters		Inches	
	Min.	Max.	Min.	Max.
A	0.889	1.295	0.035	0.051
A1	0.000	0.152	0.000	0.006
B	1.397	1.803	0.055	0.071
b	0.250	0.560	0.010	0.022
C	2.591	2.997	0.102	0.118
D	2.692	3.099	0.106	0.122
e	1.803	2.007	0.071	0.079
H	0.080	0.254	0.003	0.010
L	0.300	0.610	0.012	0.024

SOT-23-3L

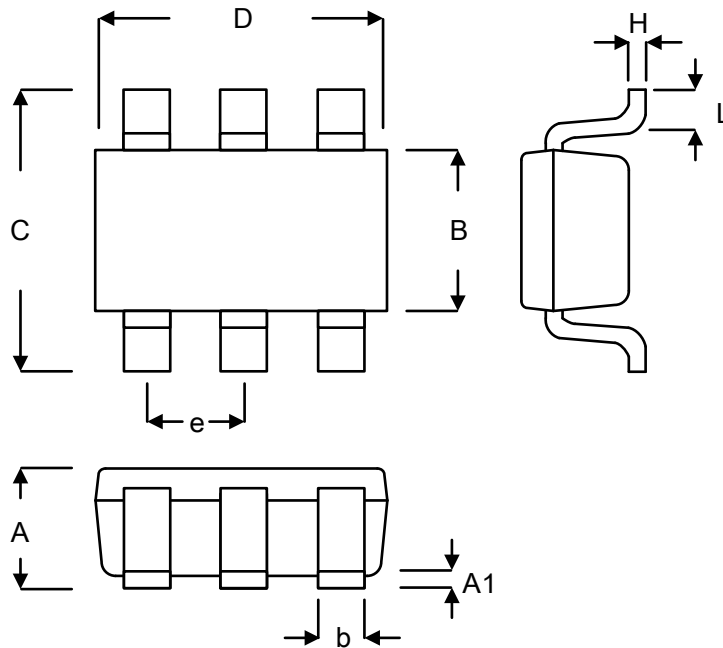

Symbol	Millimeters		Inches	
	Min.	Max.	Min.	Max.
A	0.889	1.295	0.035	0.051
A1	0.000	0.152	0.000	0.006
B	1.397	1.803	0.055	0.071
b	0.356	0.559	0.014	0.022
C	2.591	2.997	0.102	0.118
D	2.692	3.099	0.106	0.122
e	0.838	1.041	0.033	0.041
H	0.080	0.254	0.003	0.010
L	0.300	0.610	0.012	0.024

SOT-23-6L

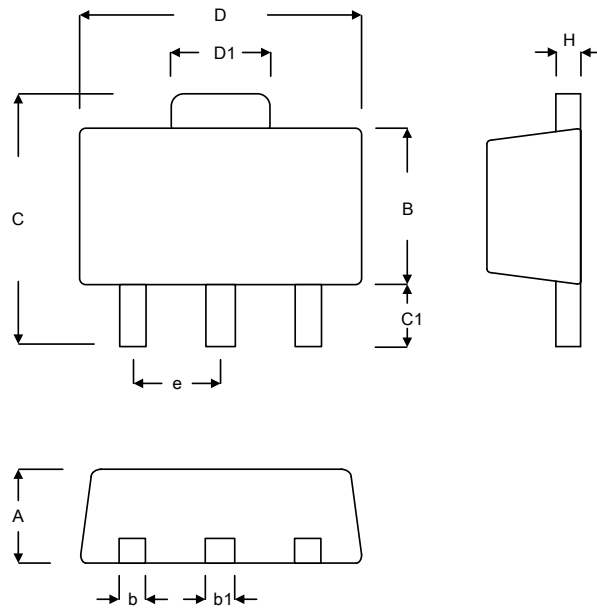

Symbol	Millimeters		Inches	
	Min.	Max.	Min.	Max.
A	1.397	1.600	0.055	0.063
b	0.356	0.483	0.014	0.019
B	2.388	2.591	0.094	0.102
b1	0.406	0.533	0.016	0.021
C	3.937	4.242	0.155	0.167
C1	0.787	1.194	0.031	0.047
D	4.394	4.597	0.173	0.181
D1	1.397	1.753	0.055	0.069
e	1.448	1.549	0.057	0.061
H	0.356	0.432	0.014	0.017

SOT-89-3L

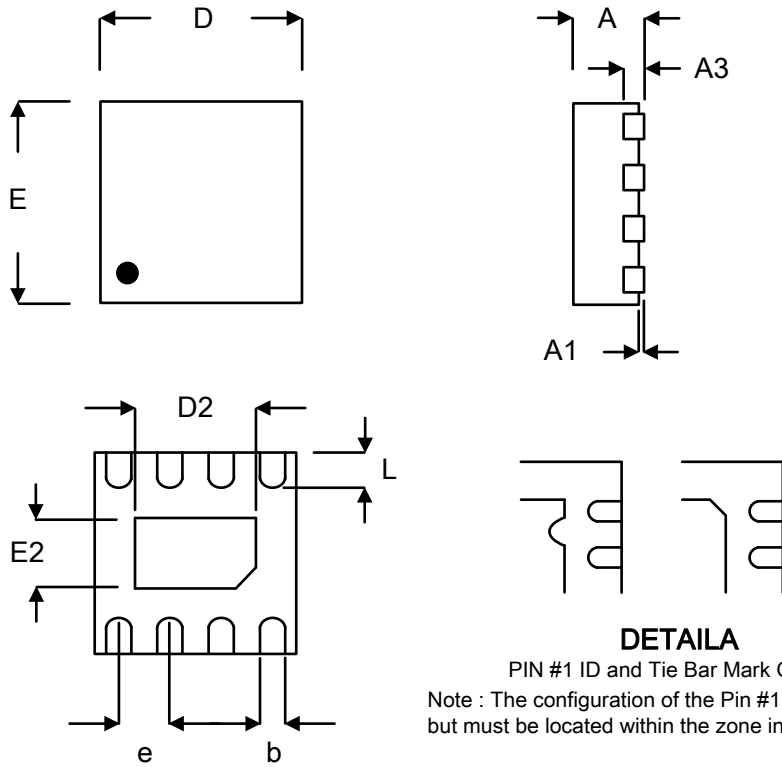
DETAILA

PIN #1 ID and Tie Bar Mark Options

Note : The configuration of the Pin #1 identifier is optional, but must be located within the zone indicated.

Symbol	Millimeters		Inches	
	Min.	Max.	Min.	Max.
A	0.700	0.800	0.028	0.031
A1	0.000	0.050	0.000	0.002
A3	0.203		0.008	
b	0.200	0.300	0.008	0.012
D	1.900	2.100	0.075	0.083
D2	1.200		0.047	
E	1.900	2.100	0.075	0.083
E2	0.700		0.028	
e	0.500		0.020	
L	0.300	0.400	0.012	0.016

DFN2x2-8L